



Programmable Controller

MELSEC iQ-R
series

MELSEC iQ-R OPC UA Server Module User's Manual (Startup)

-RD81OPC96
-SW1DND-ROPCUA-E (MX OPC UA Module Configurator-R)

SAFETY PRECAUTIONS

(Read these precautions before using this product.)

Before using this product, please read this manual and the relevant manuals carefully and pay full attention to safety to handle the product correctly.

The precautions given in this manual are concerned with this product only. For the safety precautions for the programmable controller system, refer to MELSEC iQ-R Module Configuration Manual.

In this manual, the safety precautions are classified into two levels: "⚠ WARNING" and "⚠ CAUTION".

 WARNING	Indicates that incorrect handling may cause hazardous conditions, resulting in death or severe injury.
--	--

 CAUTION	Indicates that incorrect handling may cause hazardous conditions, resulting in minor or moderate injury or property damage.
--	---

Under some circumstances, failure to observe the precautions given under "⚠ CAUTION" may lead to serious consequences.

Observe the precautions of both levels because they are important for personal and system safety.

Make sure that the end users read this manual and then keep the manual in a safe place for future reference.

[Design Precautions]

WARNING

- Configure safety circuits external to the programmable controller to ensure that the entire system operates safely even when a fault occurs in the external power supply or the programmable controller. Failure to do so may result in an accident due to an incorrect output or malfunction.
 - (1) Emergency stop circuits, protection circuits, and protective interlock circuits for conflicting operations (such as forward/reverse rotations or upper/lower limit positioning) must be configured external to the programmable controller.
 - (2) When the programmable controller detects an abnormal condition, it stops the operation and all outputs are:
 - Turned off if the overcurrent or overvoltage protection of the power supply module is activated.
 - Held or turned off according to the parameter setting if the self-diagnostic function of the CPU module detects an error such as a watchdog timer error.
 - (3) All outputs may be turned on if an error occurs in a part, such as an I/O control part, where the CPU module cannot detect any error. To ensure safety operation in such a case, provide a safety mechanism or a fail-safe circuit external to the programmable controller. For a fail-safe circuit example, refer to "General Safety Requirements" in the MELSEC iQ-R Module Configuration Manual.
 - (4) Outputs may remain on or off due to a failure of a component such as a relay and transistor in an output circuit. Configure an external circuit for monitoring output signals that could cause a serious accident.
 - In an output circuit, when a load current exceeding the rated current or an overcurrent caused by a load short-circuit flows for a long time, it may cause smoke and fire. To prevent this, configure an external safety circuit, such as a fuse.
 - Configure a circuit so that the programmable controller is turned on first and then the external power supply. If the external power supply is turned on first, an accident may occur due to an incorrect output or malfunction.
 - For the operating status of each station after a communication failure, refer to manuals relevant to the network. Incorrect output or malfunction due to a communication failure may result in an accident.
 - When connecting an external device with a CPU module or intelligent function module to modify data of a running programmable controller, configure an interlock circuit in the program to ensure that the entire system will always operate safely. For other forms of control (such as program modification, parameter change, forced output, or operating status change) of a running programmable controller, read the relevant manuals carefully and ensure that the operation is safe before proceeding. Improper operation may damage machines or cause accidents.
 - Especially, when a remote programmable controller is controlled by an external device, immediate action cannot be taken if a problem occurs in the programmable controller due to a communication failure. To prevent this, configure an interlock circuit in the program, and determine corrective actions to be taken between the external device and CPU module in case of a communication failure.
-

[Design Precautions]

WARNING

- Do not write any data to the "system area" and "write-protect area" of the buffer memory in the module. Also, do not use any "use prohibited" signals as an output signal from the CPU module to each module. Doing so may cause malfunction of the programmable controller system. For the "system area", "write-protect area", and the "use prohibited" signals, refer to the user's manual for the module used.
 - If a communication cable is disconnected, the network may be unstable, resulting in a communication failure of multiple stations. Configure an interlock circuit in the program to ensure that the entire system will always operate safely even if communications fail. Incorrect output or malfunction due to a communication failure may result in an accident.
 - To maintain the safety of the programmable controller system against unauthorized access from external devices via the network, take appropriate measures. To maintain the safety against unauthorized access via the Internet, take measures such as installing a firewall.
-

[Design Precautions]

CAUTION

- Do not install the control lines or communication cables together with the main circuit lines or power cables. Keep a distance of 100 mm or more between them. Failure to do so may result in malfunction due to noise.
 - During control of an inductive load such as a lamp, heater, or solenoid valve, a large current (approximately ten times greater than normal) may flow when the output is turned from off to on. Therefore, use a module that has a sufficient current rating.
 - After the CPU module is powered on or is reset, the time taken to enter the RUN status varies depending on the system configuration, parameter settings, and/or program size. Design circuits so that the entire system will always operate safely, regardless of the time.
 - Do not power off the programmable controller or do not reset the CPU module while the settings are being written. Doing so will make the data in the flash ROM or SD memory card undefined. The values need to be set in the buffer memory and written to the flash ROM or the SD memory card again. Doing so may cause malfunction or failure of the module.
 - When changing the operating status of the CPU module from external devices (such as the remote RUN/STOP functions), select "Do Not OPEN in Program" for "Open Method Setting" of "Module Parameter". If "OPEN in Program" is selected, an execution of the remote STOP function causes the communication line to close. Consequently, the CPU module cannot reopen the line, and external devices cannot execute the remote RUN function.
-

[Installation Precautions]

WARNING

- Shut off the external power supply (all phases) used in the system before mounting or removing the module. Failure to do so may result in electric shock or cause the module to fail or malfunction.
-

[Installation Precautions]

CAUTION

- Use the programmable controller in an environment that meets general specifications written in Safety Guidelines included in the base unit. Failure to do so may result in electric shock, fire, malfunction, or damage to or deterioration of the product.
 - To mount a module, place the concave part(s) located at the bottom onto the guide(s) of the base unit, and push in the module, and make sure to fix the module with screws since this module has no module fixing hook. Incorrect interconnection may cause malfunction, failure, or drop of the module.
 - Tighten the screws within the specified torque range. Undertightening can cause drop of the screw, short circuit, or malfunction. Overtightening can damage the screw and/or module, resulting in drop, short circuit, or malfunction.
 - When using an extension cable, connect it to the extension cable connector of the base unit securely. Check the connection for looseness. Poor contact may cause malfunction.
 - When using an SD memory card, fully insert it into the memory card slot. Check that it is inserted completely. Poor contact may cause malfunction.
 - Securely insert an extended SRAM cassette or a battery-less option cassette into the cassette connector of the CPU module. After insertion, close the cassette cover and check that the cassette is inserted completely. Poor contact may cause malfunction.
 - Do not directly touch any conductive parts and electronic components of the module, SD memory card, extended SRAM cassette, battery-less option cassette, or connector. Doing so can cause malfunction or failure of the module.
-

[Wiring Precautions]

WARNING

- Shut off the external power supply (all phases) used in the system before installation and wiring. Failure to do so may result in electric shock or cause the module to fail or malfunction.
 - After installation and wiring, attach the included terminal cover to the module before turning it on for operation. Failure to do so may result in electric shock.
-

[Wiring Precautions]

CAUTION

- Individually ground the FG and LG terminals of the programmable controller with a ground resistance of 100 ohms or less. Failure to do so may result in electric shock or malfunction.
 - Use applicable solderless terminals and tighten them within the specified torque range. If any spade solderless terminal is used, it may be disconnected when the terminal screw comes loose, resulting in failure.
 - Check the rated voltage and signal layout before wiring to the module, and connect the cables correctly. Connecting a power supply with a different voltage rating or incorrect wiring may cause fire or failure.
 - Connectors for external devices must be crimped or pressed with the tool specified by the manufacturer, or must be correctly soldered. Incomplete connections may cause short circuit, fire, or malfunction.
 - Securely connect the connector to the module. Poor contact may cause malfunction.
 - Do not install the control lines or communication cables together with the main circuit lines or power cables. Keep a distance of 100 mm or more between them. Failure to do so may result in malfunction due to noise.
 - Place the cables in a duct or clamp them. If not, dangling cables may swing or inadvertently be pulled, resulting in malfunction or damage to modules or cables.
In addition, the weight of the cables may put stress on modules in an environment of strong vibrations and shocks.
Do not clamp the extension cables with the jacket stripped. Doing so may change the characteristics of the cables, resulting in malfunction.
 - Check the interface type and correctly connect the cable. Incorrect wiring (connecting the cable to an incorrect interface) may cause failure of the module and external device.
 - Tighten the terminal screws or connector screws within the specified torque range. Undertightening can cause drop of the screw, short circuit, fire, or malfunction. Overtightening can damage the screw and/or module, resulting in drop, short circuit, fire, or malfunction.
 - When disconnecting the cable from the module, do not pull the cable by the cable part. For the cable with connector, hold the connector part of the cable. For the cable connected to the terminal block, loosen the terminal screw. Pulling the cable connected to the module may result in malfunction or damage to the module or cable.
 - Prevent foreign matter such as dust or wire chips from entering the module. Such foreign matter can cause a fire, failure, or malfunction.
 - A protective film is attached to the top of the module to prevent foreign matter, such as wire chips, from entering the module during wiring. Do not remove the film during wiring. Remove it for heat dissipation before system operation.
-

[Wiring Precautions]

CAUTION

- Programmable controllers must be installed in control panels. Connect the main power supply to the power supply module in the control panel through a relay terminal block. Wiring and replacement of a power supply module must be performed by qualified maintenance personnel with knowledge of protection against electric shock. For wiring, refer to the MELSEC iQ-R Module Configuration Manual.
 - For Ethernet cables to be used in the system, select the ones that meet the specifications in the user's manual for the module used. If not, normal data transmission is not guaranteed.
-

[Startup and Maintenance Precautions]

WARNING

- Do not touch any terminal while power is on. Doing so will cause electric shock or malfunction.
 - Correctly connect the battery connector. Do not charge, disassemble, heat, short-circuit, solder, or throw the battery into the fire. Also, do not expose it to liquid or strong shock. Doing so will cause the battery to produce heat, explode, ignite, or leak, resulting in injury or fire.
 - Shut off the external power supply (all phases) used in the system before cleaning the module or retightening the terminal screws, connector screws, or module fixing screws. Failure to do so may result in electric shock.
-

[Startup and Maintenance Precautions]

CAUTION

- When connecting an external device with a CPU module or intelligent function module to modify data of a running programmable controller, configure an interlock circuit in the program to ensure that the entire system will always operate safely. For other forms of control (such as program modification, parameter change, forced output, or operating status change) of a running programmable controller, read the relevant manuals carefully and ensure that the operation is safe before proceeding. Improper operation may damage machines or cause accidents.
 - Especially, when a remote programmable controller is controlled by an external device, immediate action cannot be taken if a problem occurs in the programmable controller due to a communication failure. To prevent this, configure an interlock circuit in the program, and determine corrective actions to be taken between the external device and CPU module in case of a communication failure.
 - Do not disassemble or modify the modules. Doing so may cause failure, malfunction, injury, or a fire.
 - Use any radio communication device such as a cellular phone or PHS (Personal Handy-phone System) more than 25cm away in all directions from the programmable controller. Failure to do so may cause malfunction.
 - Shut off the external power supply (all phases) used in the system before mounting or removing the module. Failure to do so may cause the module to fail or malfunction.
 - Tighten the screws within the specified torque range. Undertightening can cause drop of the component or wire, short circuit, or malfunction. Overtightening can damage the screw and/or module, resulting in drop, short circuit, or malfunction.
 - After the first use of the product, do not perform each of the following operations more than 50 times (IEC 61131-2/JIS B 3502 compliant). Exceeding the limit may cause malfunction.
 - Mounting/removing the module to/from the base unit
 - Inserting/removing the extended SRAM cassette or battery-less option cassette to/from the CPU module
 - Mounting/removing the terminal block to/from the module
 - After the first use of the product, do not insert/remove the SD memory card to/from the CPU module more than 500 times. Exceeding the limit may cause malfunction.
 - Do not touch the metal terminals on the back side of the SD memory card. Doing so may cause malfunction or failure of the module.
 - Do not touch the integrated circuits on the circuit board of an extended SRAM cassette or a battery-less option cassette. Doing so may cause malfunction or failure of the module.
 - Do not drop or apply shock to the battery to be installed in the module. Doing so may damage the battery, causing the battery fluid to leak inside the battery. If the battery is dropped or any shock is applied to it, dispose of it without using.
 - Startup and maintenance of a control panel must be performed by qualified maintenance personnel with knowledge of protection against electric shock. Lock the control panel so that only qualified maintenance personnel can operate it.
-

[Startup and Maintenance Precautions]

CAUTION

- Before handling the module, touch a conducting object such as a grounded metal to discharge the static electricity from the human body. Failure to do so may cause the module to fail or malfunction.
-

[Operating Precautions]

CAUTION

- When changing data and operating status, and modifying program of the running programmable controller from an external device such as a personal computer connected to an intelligent function module, read relevant manuals carefully and ensure the safety before operation. Incorrect change or modification may cause system malfunction, damage to the machines, or accidents.
 - Do not power off the programmable controller or reset the CPU module while the setting values in the buffer memory are being written to the flash ROM in the module. Doing so will make the data in the flash ROM or SD memory card undefined. The values need to be set in the buffer memory and written to the flash ROM or SD memory card again. Doing so can cause malfunction or failure of the module.
-

[Disposal Precautions]

CAUTION

- When disposing of this product, treat it as industrial waste.
 - When disposing of batteries, separate them from other wastes according to the local regulations. For details on battery regulations in EU member states, refer to the MELSEC iQ-R Module Configuration Manual.
-

[Transportation Precautions]

CAUTION

- When transporting lithium batteries, follow the transportation regulations. For details on the regulated models, refer to the MELSEC iQ-R Module Configuration Manual.
 - The halogens (such as fluorine, chlorine, bromine, and iodine), which are contained in a fumigant used for disinfection and pest control of wood packaging materials, may cause failure of the product. Prevent the entry of fumigant residues into the product or consider other methods (such as heat treatment) instead of fumigation. The disinfection and pest control measures must be applied to unprocessed raw wood.
-

CONDITIONS OF USE FOR THE PRODUCT

(1) Mitsubishi programmable controller ("the PRODUCT") shall be used in conditions;

- i) where any problem, fault or failure occurring in the PRODUCT, if any, shall not lead to any major or serious accident; and
- ii) where the backup and fail-safe function are systematically or automatically provided outside of the PRODUCT for the case of any problem, fault or failure occurring in the PRODUCT.

(2) The PRODUCT has been designed and manufactured for the purpose of being used in general industries.

MITSUBISHI SHALL HAVE NO RESPONSIBILITY OR LIABILITY (INCLUDING, BUT NOT LIMITED TO ANY AND ALL RESPONSIBILITY OR LIABILITY BASED ON CONTRACT, WARRANTY, TORT, PRODUCT LIABILITY) FOR ANY INJURY OR DEATH TO PERSONS OR LOSS OR DAMAGE TO PROPERTY CAUSED BY the PRODUCT THAT ARE OPERATED OR USED IN APPLICATION NOT INTENDED OR EXCLUDED BY INSTRUCTIONS, PRECAUTIONS, OR WARNING CONTAINED IN MITSUBISHI'S USER, INSTRUCTION AND/OR SAFETY MANUALS, TECHNICAL BULLETINS AND GUIDELINES FOR the PRODUCT.

("Prohibited Application")

Prohibited Applications include, but not limited to, the use of the PRODUCT in;

- Nuclear Power Plants and any other power plants operated by Power companies, and/or any other cases in which the public could be affected if any problem or fault occurs in the PRODUCT.
- Railway companies or Public service purposes, and/or any other cases in which establishment of a special quality assurance system is required by the Purchaser or End User.
- Aircraft or Aerospace, Medical applications, Train equipment, transport equipment such as Elevator and Escalator, Incineration and Fuel devices, Vehicles, Manned transportation, Equipment for Recreation and Amusement, and Safety devices, handling of Nuclear or Hazardous Materials or Chemicals, Mining and Drilling, and/or other applications where there is a significant risk of injury to the public or property.

Notwithstanding the above, restrictions Mitsubishi may in its sole discretion, authorize use of the PRODUCT in one or more of the Prohibited Applications, provided that the usage of the PRODUCT is limited only for the specific applications agreed to by Mitsubishi and provided further that no special quality assurance or fail-safe, redundant or other safety features which exceed the general specifications of the PRODUCTS are required. For details, please contact the Mitsubishi representative in your region.

INTRODUCTION

Thank you for purchasing the Mitsubishi Electric MELSEC iQ-R series programmable controllers.

This manual describes the performance specifications, procedure before operation, wiring, and operation examples to use the module listed below.

Before using this product, please read this manual and the relevant manuals carefully and develop familiarity with the functions and performance of the MELSEC iQ-R series programmable controller to handle the product correctly.

Please make sure that the end users read this manual.

Point

The program examples shown in this manual are the examples in which OPC UA server module (RD81OPC96) is assigned to the input/output No. X/Y0 to X/Y1F unless otherwise specified. To use the program examples shown in this manual, the input/output number assignment is required. For details on the assignment of input/output number, refer to the following manual.

 MELSEC iQ-R Module Configuration Manual

Relevant product

RD81OPC96

COMPLIANCE WITH THE EMC AND LOW VOLTAGE DIRECTIVES

Method of ensuring compliance

To ensure that Mitsubishi programmable controllers maintain EMC and Low Voltage Directives when incorporated into other machinery or equipment, certain measures may be necessary. Please refer to one of the following manuals.

- MELSEC iQ-R Module Configuration Manual
- Safety Guidelines (included in a base unit)

The CE mark on the side of the programmable controller indicates compliance with EMC and Low Voltage Directives.

Additional measures

To ensure that this product maintains EMC and Low Voltage Directives, please refer to one of the following manuals.

- MELSEC iQ-R Module Configuration Manual
- Safety Guidelines (included in a base unit)

CONTENTS

SAFETY PRECAUTIONS	1
CONDITIONS OF USE FOR THE PRODUCT	9
INTRODUCTION	10
COMPLIANCE WITH THE EMC AND LOW VOLTAGE DIRECTIVES	10
RELEVANT MANUALS	13
TERMS	14
CHAPTER 1 PART NAMES	15
CHAPTER 2 SPECIFICATIONS	17
2.1 Performance Specifications	17
Hardware specification	17
Software specification	18
2.2 Access Specifications for a CPU Module	21
Accessible CPU modules	21
Accessible routes	22
Accessible devices	27
Access units	29
CHAPTER 3 FUNCTION LIST	30
3.1 Function List of an OPC UA Server Module	30
3.2 Function List of the Configuration Tool	30
CHAPTER 4 PROCEDURE BEFORE OPERATION	32
4.1 Starting an OPC UA Server Module and an Configuration Personal Computer	33
4.2 Configuration tool	35
4.3 Parameter setting	39
4.4 SD Memory Card	41
Operation for inserting an SD memory card	41
Operation for removing or replacing an SD memory card	42
File access stop processing method	43
Insertion/removal method of an SD memory card	44
Considerations for using an SD memory card	45
CHAPTER 5 SYSTEM CONFIGURATION	47
5.1 System Configuration	47
Overall system configuration	47
System configuration for the initial setup, maintenance, and inspection	47
System configuration during operation	48
5.2 Connection device	50
5.3 Operating Environment	51
5.4 Supported Software Package	52
CHAPTER 6 WIRING	53
6.1 Wiring of an Ethernet cable	53
6.2 Wiring Considerations	54

CHAPTER 7	INSTALLATION AND UNINSTALLATION	55
7.1	Installation Procedure	55
	Environment after installation	56
7.2	Uninstallation Procedure	56
	Environment after uninstallation	56
CHAPTER 8	OPERATION EXAMPLE	57
8.1	Setup	57
	System configuration	57
	Device setup	58
8.2	Setting of an OPC UA Server Module	59
	Setting procedure	59
8.3	Operation Check	63
APPENDIX		64
Appendix 1	External Dimensions	64
INDEX		66
REVISIONS	68
WARRANTY	69
TRADEMARKS	70

RELEVANT MANUALS

Manual name [manual number]	Description	Available form
MELSEC iQ-R OPC UA Server Module User's Manual (Startup) [SH-081693ENG] (this manual)	Explains the specifications, procedure before operation, wiring, and operation examples of an OPC UA server module.	Print book e-Manual PDF
MELSEC iQ-R OPC UA Server Module User's Manual (Application) [SH-081694ENG]	Explains the functions, configuration tool, parameter setting, troubleshooting, I/O signal, and buffer memory of an OPC UA server module.	Print book e-Manual PDF

This manual does not include detailed information on the following:

- General specifications
- Applicable CPU modules and the number of mountable modules
- Applicable remote head modules and the number of mountable modules
- Installation

For details, refer to the following:

 MELSEC iQ-R Module Configuration Manual

Point

e-Manual refers to the Mitsubishi Electric FA electronic book manuals that can be browsed using a dedicated tool.

e-Manual has the following features:

- Required information can be cross-searched in multiple manuals.
- Other manuals can be accessed from the links in the manual.
- Hardware specifications of each part can be found from the product figures.
- Pages that users often browse can be bookmarked.
- Sample programs can be copied to an engineering tool.

TERMS

Unless otherwise specified, this manual uses the following terms.

Term	Description
Address space	Data that contains information of an access target device, a group, and a tag.
Application certificate	A client certificate used for application authentication in OPC UA communication. It can be uploaded to the trust list in the "Manage Application Certificate" screen of the configuration tool.
Client certificate	The certificate of an OPC UA client used for OPC UA communication. A generic term for user certificates and application certificates.
Configuration tool	An abbreviation for MX OPC UA Module Configurator-R.
Engineering tool	A tool used for setting up programmable controllers, programming, debugging, and maintenance. For the supported tools, refer to the following:  MELSEC iQ-R Module Configuration Manual
LCPU	A generic term for MELSEC-L series CPU modules.
MC Works64	A package name for Mitsubishi Electric SCADA software.
MX OPC UA Module Configurator-R	A product name for SW1DND-ROPCUA-E.
OPC	An abbreviation for OLE for Process Control. An interoperability standard for the secure and reliable exchange of data in an industrial automation field and in other industries.
OPC UA	An abbreviation for OPC Unified Architecture. Platform independent service-oriented architecture that integrates all the functionality of each OPC Classic specification into an extensible framework.
OPC UA server module	An abbreviation for RD81OPC96 OPC UA server modules.
QCPU (Q mode)	A generic term for MELSEC-Q series CPU modules and MELSEC-Q series C Controller modules.
RCPU	A generic term for MELSEC iQ-R series CPU modules and MELSEC iQ-R series C Controller modules.
RnENCPU	A generic term for R04ENCPU, R08ENCPU, R16ENCPU, R32ENCPU, and R120ENCPU.
RnPCPU	A generic term for R08PCPU, R16PCPU, R32PCPU, and R120PCPU.
SCADA	An abbreviation for Supervisory Control And Data Acquisition. An industrial control system for system monitoring and process control by using a computer.
Server certificate	The certificate of an OPC UA server used for application authentication in OPC UA communication.
Tag	Information to access device data of the CPU module of the own station or a CPU module on a network from an OPC UA client.
User certificate	A client certificate used for user authentication in OPC UA communication. A certificate can be uploaded to the trust list in the "Manage User Certificate" screen of the configuration tool.
Windows 8 or later	A generic term for Windows 8, Windows 8.1, and Windows 10.

For definitions of terms for safety CPUs, refer to the following:

 MELSEC iQ-R CPU Module User's Manual (Application)

1 PART NAMES

This chapter shows the part names of an OPC UA server module.

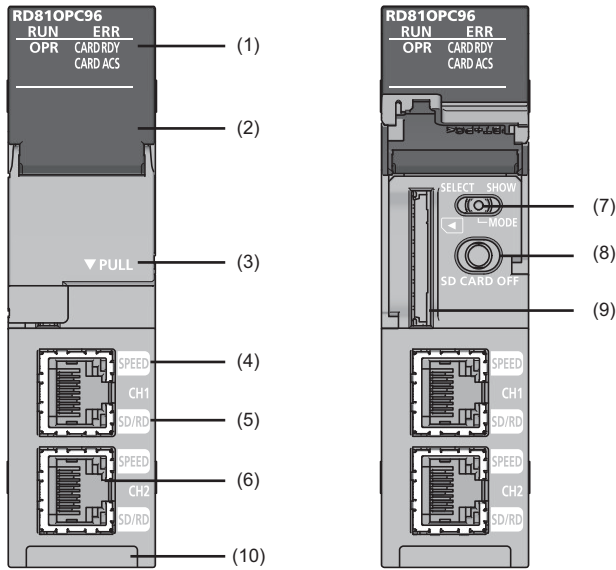

No.	Name	Description
(1)	RUN LED	Indicates the operating status. <ul style="list-style-type: none"> • ON: In operation • Flashing: In selection for online module change • OFF: Watchdog timer error (hardware failure), module replacement allowed in the process of the online module change
	ERR LED	Indicates the error status. <ul style="list-style-type: none"> • ON: Module continuation error or watchdog timer error (hardware failure) • Flashing: Module stop error • OFF: In normal status
	OPR LED	Indicates the module status. <ul style="list-style-type: none"> • ON: OPC UA server function performed • OFF: OPC UA server function stopped
	CARD RDY LED	Indicates the accessibility of an SD memory card. <ul style="list-style-type: none"> • ON: Accessible status • Flashing: In preparation or formatting • OFF: Inaccessible status (removable status) For the considerations for using an SD memory card, refer to the following: 📖 Page 45 Considerations for using an SD memory card
	CARD ACS LED	Indicates the access status of an SD memory card. <ul style="list-style-type: none"> • ON: Accessing • OFF: Not accessed
(2)	Dot matrix LED	Displays the contents of each display mode or the results of the self-diagnostic test. The following contents are displayed in each display mode. <ul style="list-style-type: none"> • Error code: Displayed in four digits in hexadecimal (When multiple errors occur, only the latest error code is displayed.) • IP address: Scrolled and displayed by 4 characters in decimal. For the display when performing the self-diagnostic test, refer to the following: 📖 MELSEC iQ-R OPC UA Server Module User's Manual (Application)
(3)	Slot cover	A cover of the SD memory card slot and the switches. Open this cover to insert/remove an SD memory card or to operate the switches. Close the cover unless inserting/removing an SD memory card or operating the switches to prevent foreign material intrusion such as dust.
(4)	SPEED LED	Indicates the communication speed and the link status for Ethernet. <ul style="list-style-type: none"> • ON (orange): Linking-up (1000 Mbps) • ON (green): Linking-up (100 Mbps) • OFF: Linking-down or linking-up (10 Mbps)
(5)	SD/RD LED	Indicates the data sending/receiving status in Ethernet. <ul style="list-style-type: none"> • ON: Sending/receiving • OFF: Not sending/receiving

No.	Name	Description
(6)	Ethernet port (CH1, CH2) ^{*1,*2}	A port for connecting an OPC UA server module to 10BASE-T/100BASE-TX/1000BASE-T. (An OPC UA server module distinguishes among 10BASE-T, 100BASE-TX, and 1000BASE-T depending on an external device.)
(7)	Dot matrix LED display mode switch (SELECT/MODE/SHOW switch)	A switch for switching the display of the dot matrix LED. <ul style="list-style-type: none"> • MODE: to display the display mode name that is currently selected. • SELECT: to select (switch) the display mode. Order: ENo. → IP1 → IP2 → ENo. • SHOW: to display the contents of the selected display mode (☞ Page 16 Dot matrix LED display) Put this display mode switch to 'SHOW' during operation, and move it only when switching the display mode.
(8)	SD memory card lock switch (SD CARD OFF button)	A switch for disabling access to an SD memory card to remove it. Removing an SD memory card is prohibited while the CARD RDY LED is ON or flashing. For the procedures for inserting and removing an SD memory card, refer to the following: ☞ Page 44 Insertion/removal method of an SD memory card
(9)	SD memory card slot	A slot to insert an SD memory card
(10)	Product information marking	Displays the product information (16 digits) of a module.

*1 Only CH1 can be connected to the configuration tool with direct connection.

*2 Only CH1 can be connected to OPC UA clients.

Dot matrix LED display

The following table shows the contents of the display mode displayed on the dot matrix LED when switching the display mode to "SHOW".

Display mode name	Description
ENo.	To display an error code.
IP1	To display the IP address of Ethernet port CH1.
IP2	To display the IP address of Ethernet port CH2.

2 SPECIFICATIONS

This chapter explains the specifications of an OPC UA server module.

2.1 Performance Specifications

This section shows the performance specifications of an OPC UA server module.

Hardware specification

Item		Specification		
SD memory card slot	Interface	SD memory card/SDHC memory card (2 GB to 16 GB)		
	Power supply	+3.3 VDC, up to 200 mA		
Ethernet port	Number of channels	2		
	Interface ^{*1}	1000BASE-T	100BASE-TX	10BASE-T
	Data transmission rate	1000 Mbps	100 Mbps	10 Mbps
	Number of cascaded stages ^{*2}	—	Maximum 2 stages	Maximum 4 stages
	Communication mode	Full-duplex/half-duplex		
	Transmission method	Base band		
	Maximum segment length ^{*3}	100 m (length between a hub and a node)		
	Applicable connector for external wiring	RJ45		
Supported function	<ul style="list-style-type: none"> • Auto-negotiation (automatic recognition of 1000BASE-T/100BASE-TX/10BASE-T) • Auto-MDI/MDI-X (automatic recognition of a straight/crossing cable) 			
Number of occupied I/O points	32 points/slot (I/O assignment: Intelli. 32 points)			
Clock	Acquired from a CPU module (CPU No.1 in a multiple CPU system).			
5 VDC internal current consumption	1.25 A			
External dimensions	Height	106mm		
	Width	27.8 mm		
	Depth	110mm		
Weight	0.25 kg			

*1 1000BASE-T/100BASE-TX/10BASE-T, and full-duplex/half-duplex communication mode are identified by an OPC UA server module depending on the hub.
 For connection with a hub not having the auto-negotiation function, set the setting on the hub side according to the communication mode.

*2 It is for a repeater hub.
 For a switching hub, consult the manufacturer of the hub used.

*3 For the maximum segment length (length between hubs), consult the manufacturer of the switching hub used.

Software specification

Item		Description	Reference
OPC UA specification		Specification for a supported OPC UA server.	Page 18 OPC UA server specification
Operation specification	Basic operation specification	Basic specification such as operations and time information handling	Page 19 Operation specification
	Device memory input/output specification	Specification for access to devices in modules such as a CPU module.	
	Conversion specification	Specification for conversion of device values in the engineering unit	
	Number specification of connected OPC UA clients	Specification for the number of connected OPC UA clients	
	Subscription specification	Specification for a subscription.	
	Application certificate specification	Specification for an application certificate.	
	User certificate specification	Specification for a user certificate.	

OPC UA server specification

An OPC UA server module supports Embedded UA Server Profile 1.03 provided by OPC Foundation.

Item	Details
Address Space Model	Address Space Base
Base Information	Base Info Core Structure
	Base Info Type System
Discovery Services	Discovery Get Endpoints
	Discovery Find Servers Self
Session Services	Session General Service Behavior
	Session Base
	Session Minimum 1
	Session Minimum 2 Parallel
View Services	View Basic
	View TranslateBrowsePath
	View RegisterNodes
	View Minimum Continuation Point 01
Attribute Services	Attribute Read
Monitored Item Services	Monitor Basic
	Monitor Value Change
	Monitored Items Deadband Filter
	Monitor Items 2
	Monitor Items 10
	Monitor Items 100
	Monitor QueueSize_1
	Monitor MinQueueSize_02
	Monitor Triggering
Subscription Services	Subscription Basic
	Subscription Minimum 1
	Subscription Minimum 02
	Subscription Publish Min 02
	Subscription Publish Min 05
	Subscription Publish Discard Policy
Protocol and Encoding	Protocol TCP Binary UA Security

Item	Details
Security	Security User Name Password
	Security Certificate Validation
	Security None
	Security None CreateSession ActivateSession
	Security Basic 128Rsa15
	Security Encryption Required
	Security Signing Required
	Security Default ApplicationInstanceCertificate
	Security User X509

Operation specification

Item	Specification		
Basic operation specification	Time information	Time	Acquired from a CPU module (CPU No.1 in a multiple CPU system).
		Time zone	
	Ethernet	Connection method	IPv4
	Configuration tool	Simultaneously connectable number	1
Connectable Ethernet port		<ul style="list-style-type: none"> • CH1 • CH2 (connection only via a hub) 	
Device memory input/output specification	Number of groups	Maximum number of definitions	10000
		Maximum number of layers	4
	Number of tags ^{*1}	Maximum number	10000
	Access target device	Maximum number	8
		Access target device type	<ul style="list-style-type: none"> • RCPU • QCPU (Q mode) • LCPU
	Polling	Maximum number of definitions	8
		Setting cycle	200 to 86400000 ms
	Conversion	Maximum number of definitions	256
Access data	Data type	<ul style="list-style-type: none"> • INT (signed 16-bit integer type) • UINT (unsigned 16-bit integer type) • REAL (32-bit floating point type) • LREAL (64-bit floating point type) • BOOL (logical type) • UDINT (unsigned 32-bit integer type) • DINT (signed 32-bit integer type) • ARRAY (one to three-dimensional array)^{*2} • STRING (ASCII character string type) • WSTRING (UTF-16 character string type) 	
	Maximum number of elements for an array/character string	128	
Conversion specification	Conversion	Conversion type	<ul style="list-style-type: none"> • None (Double type) • Linear • Square root
	Clamping	Clamping type	<ul style="list-style-type: none"> • None • Engineering unit • Details (Another engineering unit can be specified.)
Log output specification	Log retention period		14 days
	Maximum file size		99 MB
	Required free space		100 MB or more
Number specification of connected OPC UA clients	Connection setting	Maximum number of connections	15
		Connectable Ethernet port	CH1

Item		Specification	
Structure specification	Structure definition	Maximum number of settings	128
		Maximum number of members that can be set for one structure	128
		Maximum number of layers	5
		Data type of a member	<ul style="list-style-type: none"> • INT • UINT • REAL • LREAL • BOOL • UDINT • DINT • ARRAY^{*2} • STRING • WSTRING • Structure
Subscription specification		Number of subscriptions	10 per session
		Number of monitored items	<ul style="list-style-type: none"> • 3000 items per subscription • 12000 items per session • Total of 12000 items for all sessions
Application certificate specification	Trust list	Maximum number	100 (recommended)
	Revocation list	Maximum number	100 (recommended)
	Denied certificate list	Maximum number	100
User certificate specification	Trust list	Maximum number	100 (recommended)
	Revocation list	Maximum number	100 (recommended)
	Denied certificate list	Maximum number	100

*1 When using a structure label, a member of a structure is used as a tag.

*2 STRING and WSTRING cannot be specified for an element of an array.

2.2 Access Specifications for a CPU Module

This section shows the access specifications for a CPU module.

Accessible CPU modules

2

Series		Model name
RCPU	Programmable controller CPU	R00CPU, R01CPU, R02CPU, R04CPU, R04ENCPU, R08CPU, R08ENCPU, R16CPU, R16ENCPU, R32CPU, R32ENCPU, R120CPU, R120ENCPU
	Process CPU	R08PCPU, R16PCPU, R32PCPU, R120PCPU
	Safety CPU	R08SF CPU, R16SF CPU, R32SF CPU, R120SF CPU
	C Controller module	R12CCPU-V
QCPU (Q mode)	Programmable controller CPU	Q00JCPU, Q00UJCPU, Q00CPU, Q00UCPU, Q01CPU, Q01UCPU, Q02CPU, Q02HCPU, Q02UCPU, Q03UDCPU, Q03UDECPU, Q03UDVCPU, Q04UDHCPU, Q04UDEHCPU, Q04UDVCPU, Q06HCPU, Q06UDHCPU, Q06UDEHCPU, Q06UDVCPU, Q10UDHCPU, Q10UDEHCPU, Q12HCPU, Q13UDHCPU, Q13UDEHCPU, Q13UDVCPU, Q20UDHCPU, Q20UDEHCPU, Q25HCPU, Q26UDHCPU, Q26UDEHCPU, Q26UDVCPU, Q50UDEHCPU, Q100UDEHCPU
	Process CPU	Q02PHCPU, Q04UDPVCPU, Q06PHCPU, Q06UDPVCPU, Q12PHCPU, Q13UDPVCPU, Q25PHCPU, Q26UDPVCPU
	C Controller module ^{*1}	Q12DCCPU-V ^{*2} , Q24DHCCPU-V, Q24DHCCPU-LS, Q24DHCCPU-VG, Q26DHCCPU-LS
LCPU	Programmable controller CPU	L02SCPU, L02SCPU-P, L02CPU, L02CPU-P, L06CPU, L06CPU-P, L26CPU, L26CPU-P, L26CPU-BT, L26CPU-PBT

*1 It cannot be used as a relay station.

*2 Only a module with a serial number of which the first five digits are 12042 or higher can be accessed.



When using a multiple CPU system, refer to the following:

MELSEC iQ-R Module Configuration Manual

Accessible routes

The following figure shows accessible routes from an OPC UA server module.

- ← : Access route from an OPC UA server module
- - - : Connection from an Ethernet port of an OPC UA server module
- - - : Connection by specifying the network number and the station number of a target station
- - - : Connection by specifying the start I/O No. of a module to be routed and the station number of a target station

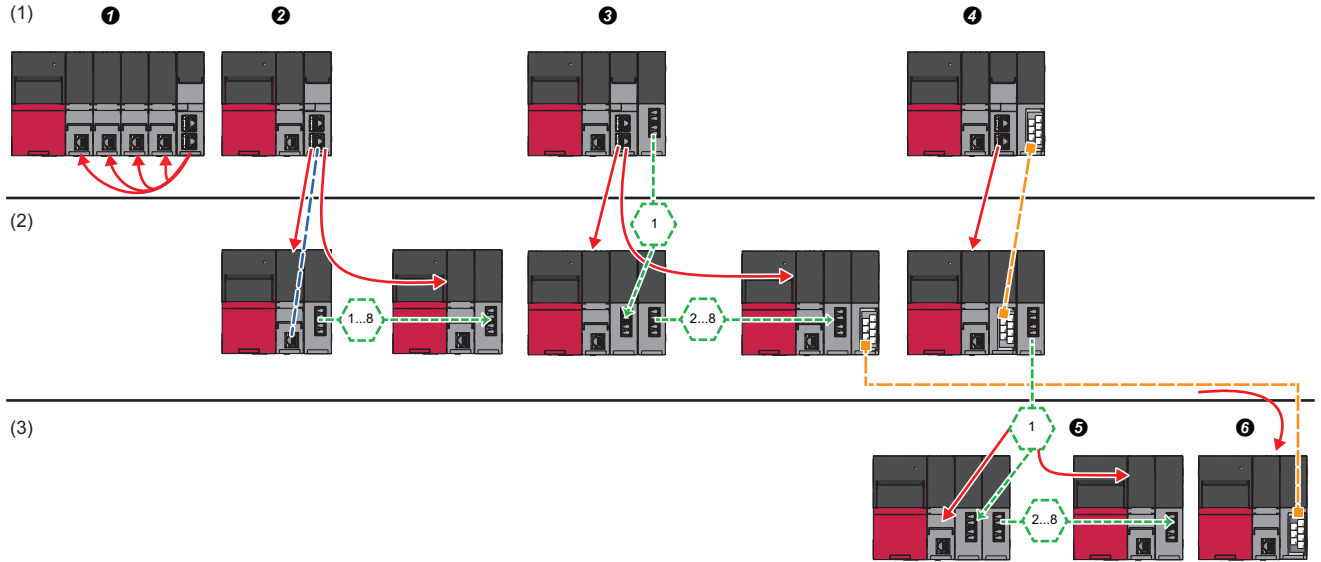

Accessible route		Reference	
(1)	Own station (control CPU, another CPU in a multiple CPU system)	Page 23 Own station (control CPU, another CPU in a multiple CPU system)	
(2)	Another station via a single network	② Access via an Ethernet port of an OPC UA server module	Page 24 Access via an Ethernet port of an OPC UA server module
		③ Access by specifying the network number and the station number of a target station (CC-Link IE Controller Network module, CC-Link IE Field Network module, or Ethernet interface module)	Page 25 Access by specifying the network number and the station number of a target station
		④ Access by specifying the start I/O No. of a module to be routed and the station number of a target station (CC-Link module)	Page 25 Access by specifying the start I/O number of a module to be routed and the station number of a target station
(3)	Another station via a co-existence network	⑤ Access from the station accessed in ④ by specifying the network number and the station number of a target station	Page 26 Access by specifying the network number and the station number via another station on CC-Link
		⑥ Access from the station accessed in ③ by specifying the start I/O No. of a module that is routed through and the station number of a target station	Page 26 Access from another station specified by the network number and the station number on CC-Link

Own station (control CPU, another CPU in a multiple CPU system)

The following table shows the accessibility to a CPU module of a station that an OPC UA server module is mounted.

○: Accessible, —: No combination

Access route	Access target device type (series)				
	RCPU		QCPU (Q mode)		LCPU
	Programmable controller CPU/ Process CPU/ Safety CPU	C Controller module	Programmable controller CPU/ Process CPU	C Controller module	Programmable controller CPU
Control CPU	○	○	—	—	—
Another CPU in a multiple CPU system	○*1 (CPU No.1 to 4)	○ (CPU No.1 to 4)	—	—	—

*1 No combination with an RnENCPU.

Another station via a single network

■ Access via an Ethernet port of an OPC UA server module

A target device can be accessed via an Ethernet port of an OPC UA server module in the status where the target device is connected to a network.

For the communication destination from an Ethernet port of an OPC UA server module, an Ethernet interface module or a CPU module (Ethernet port) can be specified.

For accessing a target station, direct access and access via another system^{*1} are available.

*1 It is not available when the series of an access target device and a system to be routed differ.

(Example) Access is available when the series of a target device and a system to be routed are 'QCPU'.

○: Accessible, —: No combination

Access route			Access target device type (series)						
			RCPU		QCPU (Q mode)		LCPU		
			Programmable controller CPU/ Process CPU/ Safety CPU	C Controller module	Programmable controller CPU/ Process CPU	C Controller module	Programmable controller CPU		
Ethernet	Ethernet port of an OPC UA server module → Ethernet interface module	Direct	○ ^{*2} (CPU No.1 to 4)	—	○ (CPU No.1 to 4)	—	○		
		Via another system		CC-Link IE Controller Network		○ (CPU No.1 to 4)	○ (CPU No.1 to 4)	—	
				CC-Link IE Field Network		—	—	○	
	Ethernet ^{*3}			—		—	○		
	Ethernet port of an OPC UA server module → CPU module (Ethernet port)	Direct		○ (CPU No.1 to 4)		○ (CPU No.1 to 4)	○ ^{*4} (CPU No.1 to 4)	○	○
		Via another system						CC-Link IE Controller Network	—
CC-Link IE Field Network			—		○				
Ethernet ^{*3}	—		○						

*2 It can access to an RnENCPU only in a single CPU system.

*3 It is also supported by a QCPU (Q mode) for which the MELSOFT connection extended setting was set.

*4 To access an Ethernet port of Q12DCCPU-V (Basic mode) directly, MELSOFT connection must be allowed in the Q12DCCPU-V (Basic mode) setting.

For details on the setting, refer to the following:

📖 C Controller Module User's Manual (Utility Operation, Programming)

■ Access by specifying the network number and the station number of a target station

A target device can be accessed via a relay station when the target device is connected within eight networks from a station, on which an OPC UA server module is mounted, and can be identified by the network number and the station number (or CPU number).

○: Accessible, —: No combination

Access route	Access target device type (series)				
	RCPU		QCPU (Q mode)		LCPU
	Programmable controller CPU/ Process CPU/ Safety CPU	C Controller module	Programmable controller CPU/ Process CPU	C Controller module	Programmable controller CPU
CC-Link IE Controller Network	○*1 (CPU No.1 to 4)	○ (CPU No.1 to 4)	○ (CPU No.1 to 4)	○ (CPU No.1 to 4)	—
CC-Link IE Field Network		—		—	○
Ethernet*2,*3					○

*1 It can access to an RnENCPU only in a single CPU system.

*2 It is also supported by a QCPU (Q mode) for which the MELSOFT connection extended setting was set.

*3 Only CH2 of an OPC UA server module is accessible for the Ethernet route.

■ Access by specifying the start I/O number of a module to be routed and the station number of a target station

The following table shows the accessible routes to connect with a target device and a station on which an OPC UA server module is mounted directly.

○: Accessible, —: No combination

Access route	Access target device type (series)				
	RCPU		QCPU (Q mode)		LCPU
	Programmable controller CPU/ Process CPU/ Safety CPU	C Controller module	Programmable controller CPU/ Process CPU	C Controller module	Programmable controller CPU
CC-Link	○*1 (CPU No.1 to 4)	○ (CPU No.1 to 4)	○ (CPU No.1 to 4)	○ (CPU No.1 to 4)	○

*1 It can access to an RnENCPU only in a single CPU system.

Another station via a co-existence network

■ Access by specifying the network number and the station number via another station on CC-Link

The following table shows the accessible route to a target station from a station, on which an OPC UA server module is mounted, by specifying the network number and the station number of the target station. In this route, another station on CC-Link is accessed first (first route), then the target station is accessed from there.

○: Accessible, —: No combination

First access route	Second access route (co-existence network)	Access target device type (series)				
		RCPU		QCPU (Q mode)		LCPU
		Programmable controller CPU/ Process CPU/ Safety CPU	C Controller module	Programmable controller CPU/ Process CPU	C Controller module	Programmable controller CPU
CC-Link	CC-Link IE Controller Network	○*1 (CPU No.1 to 4)	○ (CPU No.1 to 4)	○ (CPU No.1 to 4)	○ (CPU No.1 to 4)	—
	CC-Link IE Field Network					○
	Ethernet*2		—		—	○

*1 It can access to an RnENCPU only in a single CPU system.

*2 It is also supported by a QCPU (Q mode) for which the MELSOFT connection extended setting was set.

■ Access from another station specified by the network number and the station number on CC-Link

The following table shows the accessible route to a target station from a station, on which an OPC UA server module is mounted, by specifying the start I/O No. of a module that is routed through and the station number of the target station. In this route, another station on CC-Link is accessed first by specifying the network number and the station number (first route), then the target device is accessed from there.

○: Accessible, —: No combination

First access route	Second access route (co-existence network)	Access target device type (series)				
		RCPU		QCPU (Q mode)		LCPU
		Programmable controller CPU/ Process CPU/ Safety CPU	C Controller module	Programmable controller CPU/ Process CPU	C Controller module	Programmable controller CPU
CC-Link IE Controller Network	CC-Link	○*1 (CPU No.1 to 4)	○ (CPU No.1 to 4)	○ (CPU No.1 to 4)	○ (CPU No.1 to 4)	—
CC-Link IE Field Network						○
Ethernet*2,*3			—		—	○

*1 It can access to an RnENCPU only in a single CPU system.

*2 It is also supported by a QCPU (Q mode) for which the MELSOFT connection extended setting was set.

*3 Only CH2 of an OPC UA server module is accessible for the Ethernet route.

Accessible devices

The following table shows the accessible devices.

○: Accessible, ×: Not accessible, —: No device

Device (device name)		Access target device type (series)				
		RCPU		QCPU (Q mode)		LCPU
		Programmable controller CPU/ Process CPU/ Safety CPU ^{*1}	C Controller module	Programmable controller CPU/ Process CPU	C Controller module	Programmable controller CPU
Function input (FX)		×	×	×	×	×
Function output (FY)		×	×	×	×	×
Function register (FD)		×	×	×	×	×
Special relay (SM)		○	○	○	○	○
Special register (SD)		○	○	○	○	○
Input relay (X)		○	○	○	○	○
Output relay (Y)		○	○	○	○	○
Internal relay (M)		○	○	○	○	○
Latch relay (L)		○	—	○	—	○
Annunciator (F)		○	—	○	—	○
Edge relay (V)		○	—	○	—	○
Link relay (B)		○	○	○	○ ^{*2}	○
Data register (D)		○	○	○	○	○
Link register (W)		○	○	○	○ ^{*2}	○
Timer	Contact (TS)	○	—	○	—	○
	Coil (TC)	○	—	○	—	○
	Current value (T/TN)	○	—	○	—	○
Long timer	Contact (LTS)	○	—	—	—	—
	Coil (LTC)	○	—	—	—	—
	Current value (LT/LTN)	○	—	—	—	—
Counter	Contact (CS)	○	—	○	—	○
	Coil (CC)	○	—	○	—	○
	Current value (C/CN)	○	—	○	—	○
Long counter	Contact (LCS)	○	—	—	—	—
	Coil (LCC)	○	—	—	—	—
	Current value (LC/LCN)	○	—	—	—	—
Retentive timer	Contact (STS, SS ^{*3})	○	—	○	—	○
	Coil (STC, SC ^{*3})	○	—	○	—	○
	Current value (ST/STN, ST/SN ^{*3})	○	—	○	—	○
Long retentive timer	Contact (LSTS)	○	—	—	—	—
	Coil (LSTC)	○	—	—	—	—
	Current value (LST/LSTN)	○	—	—	—	—
Link special relay (SB)		○	—	○	—	○
Link special register (SW)		○	—	○	—	○
Step relay (S)		—	—	×	—	×
Index register (Z)		○	—	○	—	○
Long index register (LZ)		×	—	—	—	—
File register	(R)	○	—	○	—	○
	(ZR)	○	○	○	—	○

Device (device name)		Access target device type (series)				
		RCPU		QCPU (Q mode)		LCPU
		Programmable controller CPU/ Process CPU/ Safety CPU ^{*1}	C Controller module	Programmable controller CPU/ Process CPU	C Controller module	Programmable controller CPU
Link direct device	Link input (Jn\X)	○	○	○	○	○
	Link output (Jn\Y)	○	○	○	○	○
	Link relay (Jn\B)	○	○	○	○	—
	Link special relay (Jn\SB)	○	○	○	○	○
	Link register (Jn\W)	○	○	○	○	○
	Link special register (Jn\SW)	○	○	○	○	○
Module access device	Module access device/ Intelligent function module device (Un\G)	○	○	○	○	○
	Multiple CPU shared device (U3En\G)	—	—	○	○	—
CPU buffer memory access device	CPU buffer memory access device (U3En\G)	○	○	—	—	—
	CPU buffer memory access device (fixed cycle communication area) (U3En\HG)	○ ^{*4}	○	—	—	—
Refresh data register (RD)		×	×	—	—	—

*1 Safety devices cannot be accessed.

*2 Q12DCCPU-V (Basic mode) has no device.

*3 A device name for QCPUs (Q mode) and LCPUs

*4 RnENCPUs and safety CPUs have no device.

Access units

The following table shows the number of accessible device points (access units) in one process (one scanning) when accessing the device memory in a CPU module.

The access units of a CPU module other than the following modules depend on the module type.

Access target device type (series)		Device reading	Device writing
RCPU	Programmable controller CPU	118 points ^{*1}	78 points ^{*1}
	Process CPU	58 points ^{*2}	38 points ^{*2}
	Safety CPU		
	C Controller module		

*1 Access from a device other than an Ethernet port of an OPC UA server module

*2 Access via an Ethernet port of an OPC UA server module

Data inconsistency

When the number of accessed device points is equal to the access unit or less, device values in a same sequence scan are obtained and applied.

When the number of device points exceeds the access unit, device values may be obtained from multiple sequence scans and applied, which may cause data inconsistency.

■When data inconsistency is a problem

Set the following when a sequence program and the data needs to be synchronized and data inconsistency is a problem.

- Set the number of device points accessed at the same time to the access unit or less.

3 FUNCTION LIST

This chapter shows the function list of an OPC UA server module and the configuration tool.

For details on the functions, refer to the following:

📖 MELSEC iQ-R OPC UA Server Module User's Manual (Application)

3.1 Function List of an OPC UA Server Module

This section shows the function list of an OPC UA server module.

Function	Description	
OPC UA server function	Data Access function	To access a tag (device of a CPU module such as that of the own station or on network) and a structure label registered in the address space from an OPC UA client.
	Conversion function	To convert device values in the engineering unit.
Security function	User authentication function	To prevent illegal access to an OPC UA server module by a user name and a password.
Other functions	Self-diagnostic function	To diagnose whether a module operates normally.
	SD memory card format function	To format an SD memory card.
	Online module change function	To replace a module with another without stopping a running system. For the procedure, refer to the following: 📖 MELSEC iQ-R Online Module Change Manual

3.2 Function List of the Configuration Tool

This section shows the function list of the configuration tool.

Function	Description	
Address space setting function	Tree view	To display address space information and each definition in a tree.
	List view	To display a child item of an item selected on the tree view in a list.
	Access target device communication setting	To set a communication setting for an access target device.
	Tag	To create a tag and assign a device number, and a polling definition etc.
	Structure label	To create a structure label by using a structure definition. A member of a structure can be used as a tag.
	Group	To manage tags by grouping and hierarchizing them.
	Array	To use a tag as an array. Members of a structure and structure labels can also be used as arrays.
Structure	To manage the data structure of a set structure definition.	
Conversion setting function	To set a conversion definition. A set definition is used for the address space setting.	
Polling definition setting function	To set a polling definition. A set definition is used for the address space setting.	
Structure definition setting function	To set a structure definition. A set definition is used for the address space setting.	
Global label and common device comment import function	To import global labels and common device comments that are set in an engineering tool into a setting of an OPC UA server module.	
OPC UA server operation function	Online	To perform the following operations on an OPC UA server module. <ul style="list-style-type: none"> • Starting an server operation • Stopping an server operation • Restarting an server operation • Reading setting data • Writing setting data
	Certificate	To create and manage a certificate.
Log view function	To display a communication log with an OPC UA server module in the log view.	
Help function	Help	To open MELSEC iQ-R OPC UA Server Module User's Manual.
	Version information	To display the version information of the configuration tool.

4 PROCEDURE BEFORE OPERATION

This chapter shows the procedure before operating an OPC UA server module.

4.1 Starting an OPC UA Server Module and an Configuration Personal Computer

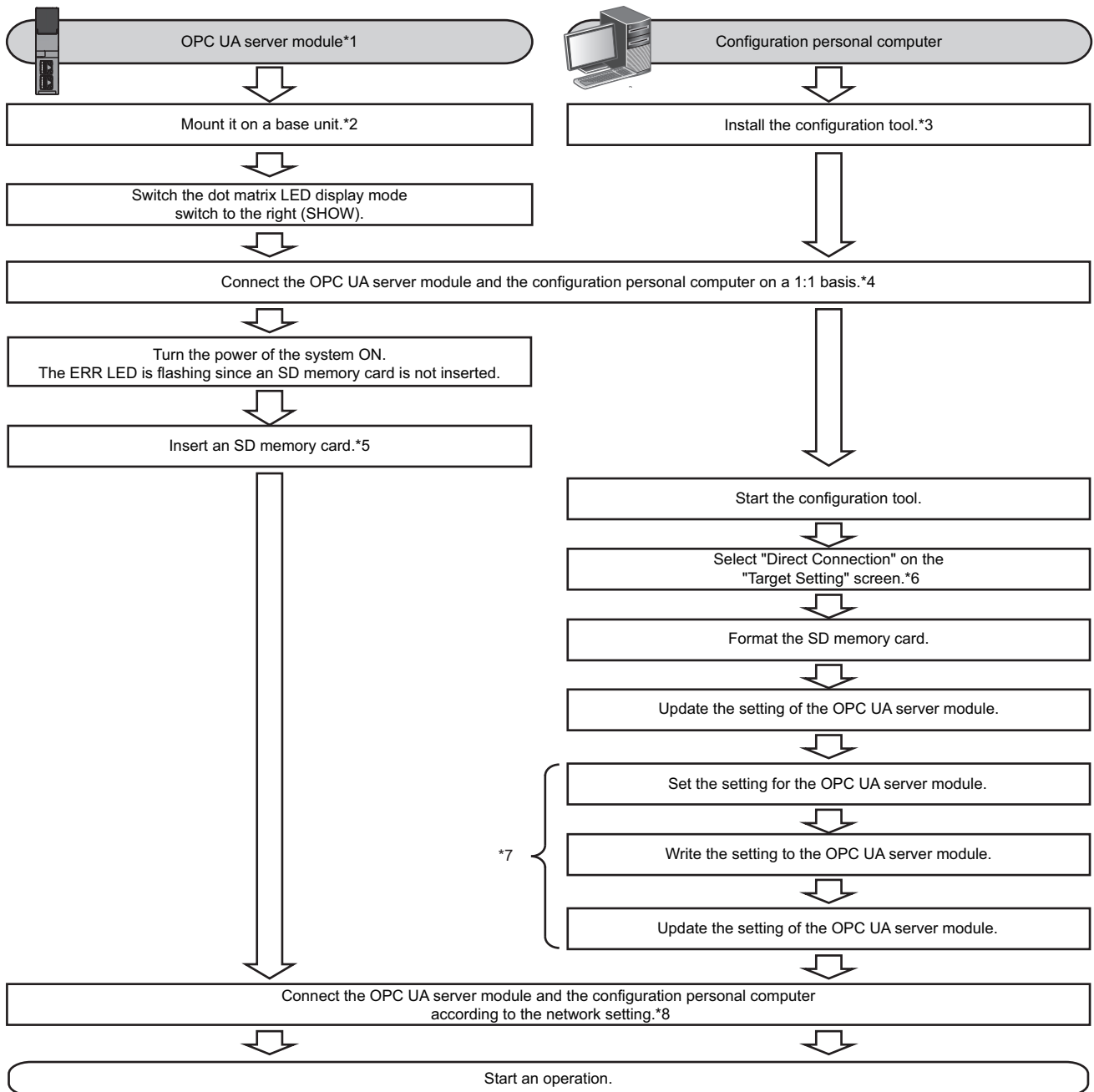

*1 Perform the self-diagnostic test as necessary. (MELSEC iQ-R OPC UA Server Module User's Manual (Application))

*2 Do not use an electric screwdriver to attach and remove module fixing screws.

*3 Page 55 INSTALLATION AND UNINSTALLATION

*4 Page 47 System configuration for the initial setup, maintenance, and inspection

*5 Page 41 SD Memory Card

*6 Specify the following (the default security setting) for connection on the "Connection Setting" screen of the configuration tool. Use the user authentication :Select the checkbox.

User name: RD81OPC96

Password: MITSUBISHI

*7 Perform these steps to change the setting of an OPC UA server module.

*8 Page 34 Network setting for connection

Network setting for connection

The following shows the network setting for a configuration personal computer when connecting the computer to an OPC UA server module via a hub.

Operating procedure

1. Set the same value for the network portion of the IP addresses for a configuration personal computer and an OPC UA server module.

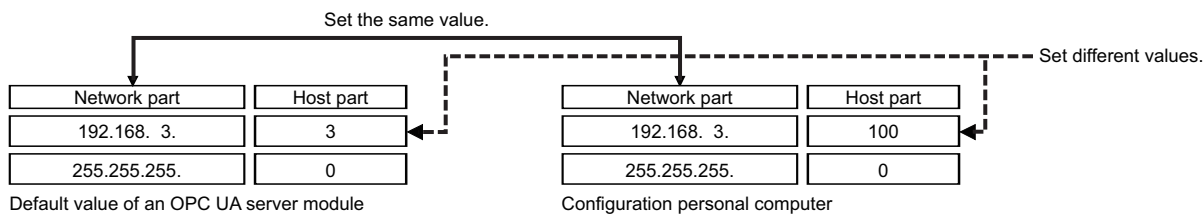

2. Set the network setting for the configuration personal computer on the "Internet Protocol Version 4 (TCP/IPv4) Properties" screen.

(Example) Microsoft Windows 7 Ultimate

- 1 Select [Control Panel] ⇒ "Network and Internet" ⇒ "Network and Sharing Center" ⇒ "Change adapter settings".
- 2 Select "Local Area Connection" and click [Properties] on the right click menu.
- 3 Select "Internet Protocol Version 4 (TCP/IPv4)" on the "Local Area Connection Properties" screen, and click the [Property] button.
- 4 The "Internet Protocol Version 4 (TCP/IPv4) Properties" screen appears.

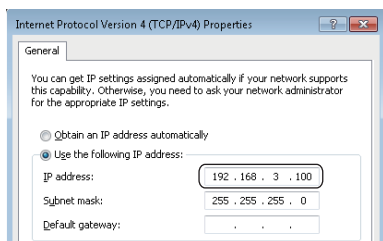

3. Restart the personal computer to enable the network setting.

4.2 Configuration tool

This section shows the configuration tool to set the OPC UA server setting of an OPC UA server module.
For details on the configuration tool, refer to the following:

📖 MELSEC iQ-R OPC UA Server Module User's Manual (Application)

Startup method

Operating procedure

1. Select [MELSOFT] ⇒ [MX OPC UA]^{*2} ⇒ [MELSEC iQ-R series OPC UA Server Module Configuration Tool] from Windows Start^{*1}.

*1 Select [All apps] in the Start screen or [Start] ⇒ [All Programs]/[All apps].

*2 Does not appear in Windows 8 or later.

Display Language Switching

The configuration tool supports multiple languages, and therefore the display language such as one on the menu can be switched on a personal computer.

Window

[View] ⇒ [Switch Display Language]

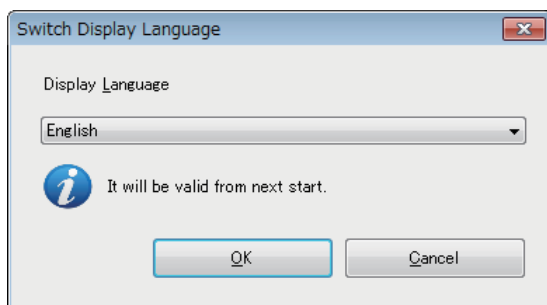

Precautions

If the display language differs from the one for the operating system, texts may not displayed properly on the screen.
(Displayed texts may get cut.)

Screen configuration

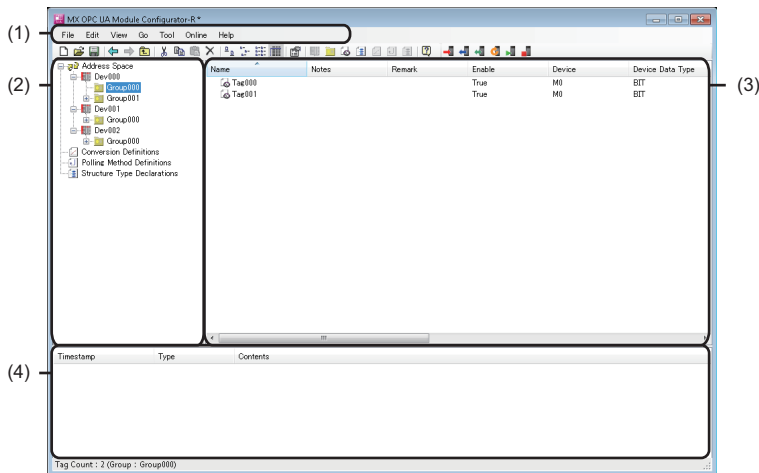

- (1) Menu bar
- (2) Tree view
- (3) List view
- (4) Log view

■ Menu configuration

Item		Description
File	New	To discard a project being edited and create a new project.
	Open Project	To open a project file saved in a personal computer.
	Save	To overwrite and save a project being edited in a file.
	Save as	To name and save a project being edited.
	Close	To close a project being edited.
	(recently opened project)	To open a project file used recently in the configuration tool.
	Exit	To end the configuration tool.
Edit	New Target Device	To add a new access target device.
	New Group	To add a new group.
	New Data Tag	To add a new tag.
	New Structure Type Declarations	To add a new structure label.
	New Conversion Definitions	To add a new conversion definition.
	New Polling Method Definitions	To add a new polling definition.
	New Structure Type Declarations	To add a new structure definition.
	Cut	To cut a selected item and copy it to the clipboard.
	Copy	To copy a selected item to the clipboard.
	Paste	To paste an item on the clipboard.
	Select All	To select all objects on the list.
	Invert Selection	To switch items to be highlighted.
	Delete	To delete a selected item.
	Import Global Label	To import global labels as data from a project file in an engineering tool.
	Release Relation to Global Label	To release the relation between data and an import source global label.
	Update Data Related to Global Label	To update data to the latest value when a value in an import source global label is changed.
Import Common Device Comment	To import common device comments as data from a project file in an engineering tool.	
Properties	To display the property of a selected item.	

Item		Description
View	Basic Function Bar	To show/hide the buttons for basic functions.
	Online Operating Bar	To show/hide the buttons for online operation.
	Status Bar	To show/hide the status bar.
	Log	To show/hide the log view.
	Large Icons	To change the icons on the list view to the large ones.
	Small Icons	To change the icons on the list view to the small ones.
	List	To display an item on the list view in a list.
	Details	To display an item on the list view in detail.
	Sort	To sort an item on the list view by specifying a row.
	Row	To select a row to display on the list view.
	Switch Display Language	To switch the display language.
	Go	Back
Forward		To go back to the previously selected item. To restore the operation of 'Back'.
Up One Level		To move up one level in the tree view.
Next Item		To move to the next item in the tree view.
Previous Item		To move to the previous item in the tree view.
Expand Item		To expand a selected item in the tree view.
Collapse Item		To collapse a selected item in the tree view.
Home		To move to the top item in the tree view.
End		To move to the bottom item in the tree view.
Address Space		To move to "Address Space" in the tree view.
Conversion Definitions		To move to "Conversion Definitions" in the tree view.
Polling Method Definitions		To move to "Polling Method Definitions" in the tree view.
Structure Type Declarations		To move to "Structure Type Declarations" in the tree view.
Tool		Security Setting
	Network Setting	To set the setting required for a network connection.
	OPC UA Server Setting	To set the setting related to an OPC UA server which operates on an OPC UA server module.
Online	Target Setting	To set the setting to connect to an OPC UA server module.
	Read from OPC UA Server Module	To read the server setting from an OPC UA server module.
	Write to OPC UA Server Module	To write the server setting to an OPC UA server module.
	Verify with OPC UA Server Module	To verify the server setting in an OPC UA server module with that in the configuration tool.
	Update setting of OPC UA Server Module	To update a setting of an OPC UA server module.
	Restart the OPC UA Server Module	To restart a server operation of an OPC UA server module.
	Stop the OPC UA Server Module	To stop a server operation of an OPC UA server module.
	OPC UA Server Module Information	To display the current connection status.
	SD Memory Card Diagnosis	To display the current use status of the SD memory card inserted in an OPC UA server module and format the SD memory card.
	Manage Application Certificate	To manage application certificates in an OPC UA server module.
	Manage User Certificate	To manage user certificates in an OPC UA server module.
Help	Help	To open the user's manual of an OPC UA server module.
	Version Information	To display the version information of the configuration tool.

■Tree view

Address space information and each definition is displayed in a tree.

■List view

A child item of an item selected in the tree view is displayed in a list.

Clicking the header of each column can sort items in ascending or descending order by comparing character strings. Note that clicking the header of the "Device" column sorts items by comparing character strings of device names and numerical values of device numbers.

■Log view

A communication event log between the configuration tool and an OPC UA server module is displayed (up to 500 logs).

If 500 or more events occur, an old log is deleted in chronological order.

Item	Description
Time stamp	To display the date and time when an event occurred.
Type	To display the type of an event. <ul style="list-style-type: none">• Information: Information message such as a communication parameter• Warning: Warning level message• Error: Error level message
Contents	To display the contents of an event.

4.3 Parameter setting

This section shows the mode setting of an OPC UA server module in the parameter setting of an engineering tool.
For details on the parameter setting, refer to the following:

📖 MELSEC iQ-R OPC UA Server Module User's Manual (Application)

Startup method

Operating procedure

1. Select [MELSOFT] ⇒ [GX Works3]^{*2} ⇒ [GX Works3] from Windows Start^{*1}.

*1 Select [All apps] in the Start screen or [Start] ⇒ [All Programs]/[All apps].

*2 Does not appear in Windows 8 or later.

Parameter setting

Operating procedure

1. Create a new project.

🖱️ [Project] ⇒ [New]

2. Select a series, a type, and a program language, click the [OK] button.

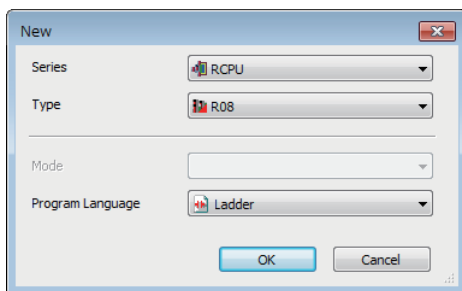

3. Set whether to use module labels, click the [OK] button.

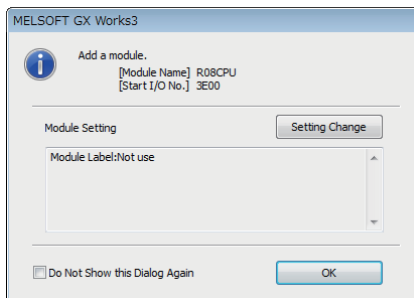

4. Display the "Add New Module" screen.

🖱️ [Navigation window] ⇒ [Parameter] ⇒ right-click [Module Information] ⇒ [Add New Module]

5. Add an OPC UA server module.

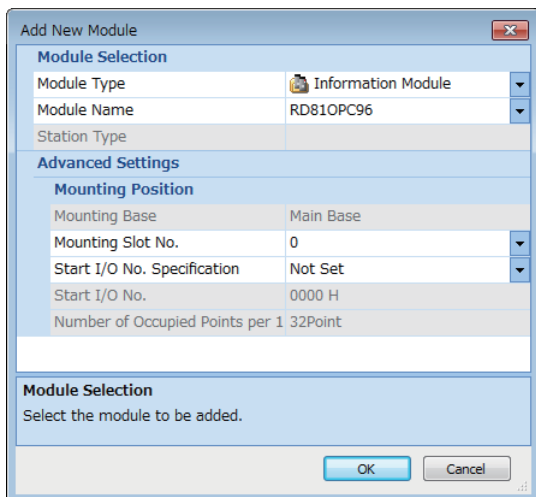

Item	Description
Module Type	Select "Information Module".
Module Name	Select "RD81OPC96".
Mounting Slot No.	Select the slot number where an OPC UA server module is mounted.
Start I/O No. Specification	Select "Not Set" when not specifying the start I/O number of an OPC UA server module, otherwise, select "Set".
Start I/O No.	When selecting "Set" for "Start I/O No. specification", enter the start I/O number of an OPC UA server module.

6. Set whether to use module labels, click the [OK] button.

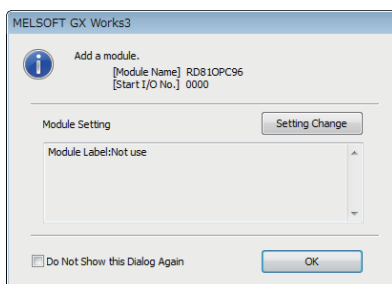

7. Set the module parameter of an OPC UA server module.

[Navigation window] ⇒ [Parameter] ⇒ [Module Information] ⇒ [RD81OPC96]

8. After setting the parameter, write the setting to a CPU module from an engineering tool.

9. Reset or turn OFF to ON the CPU module to apply the setting.

4.4 SD Memory Card

This section shows an SD memory cards to insert and use in an OPC UA server module.
For available SD memory cards and considerations, refer to the following:

- ☞ Page 50 SD memory card (sold separately, required)
- ☞ Page 45 Considerations for using an SD memory card

Operation for inserting an SD memory card

The following shows the method for inserting an SD memory card.

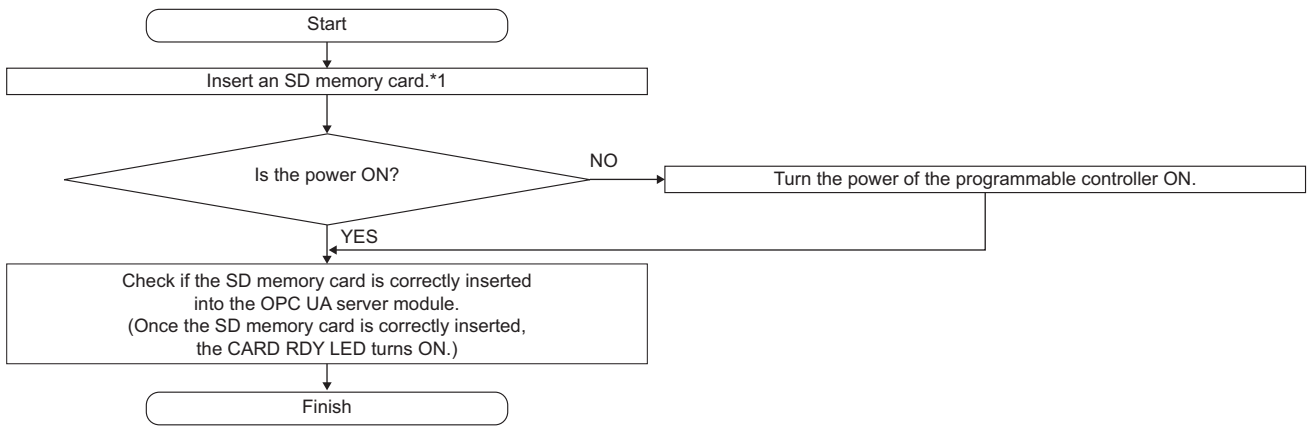

*1 ☞ Page 44 Insertion procedure

Operation for removing or replacing an SD memory card

Make sure to stop the file access by following the procedure as shown below when removing or replacing an SD memory card.

If the power is OFF and the file access is not stopped, turn the power ON and stop the file access.

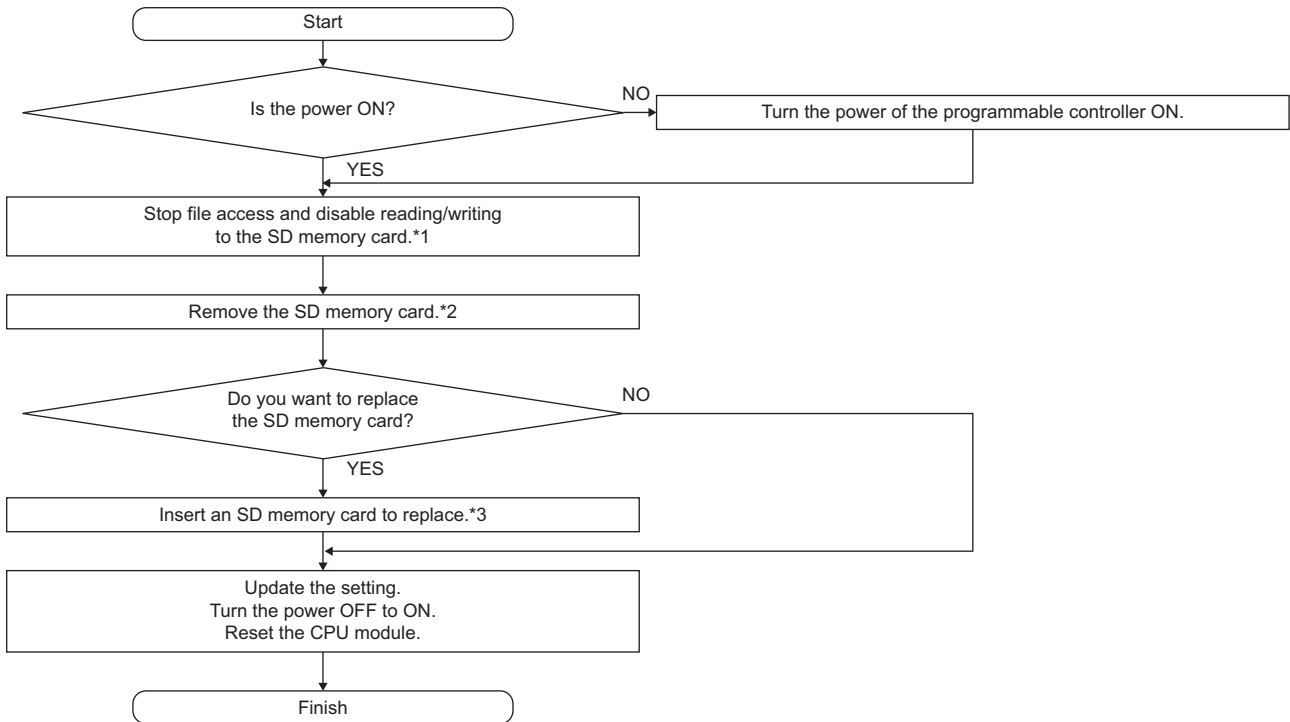

*1 Page 43 File access stop processing method

*2 Page 44 Removal procedure

*3 Page 44 Insertion procedure

Point

- If an error occurs on an SD memory card, refer to the following:
(MELSEC iQ-R OPC UA Server Module User's Manual (Application))
- The setting of an OPC UA server module is saved in an SD memory card. Therefore, if the CPU module is turned OFF to ON or reset when any SD memory card is inserted or any setting is not written to the SD memory card, the IP address of the OPC UA server module returns to the default (192.168.3.3).
As necessary, read the current setting before removing an SD memory card. Then, promptly write the setting to the new card after the replacement.

File access stop processing method

The following are the methods to stop file access.

- Using the switch on the front of a module
- Using the I/O (X/Y) signal

Method by using the switch on the front of a module

1. Press the SD memory card lock switch for one second or more.
2. Check that the CARD RDY LED is turned OFF.

Method by using the I/O (X/Y) signal

1. Turn 'File access stop request' (Y3) OFF to ON.
2. Check that 'File access status' (X3) turns OFF to ON or the CARD RDY LED turns OFF.
3. Turn 'File access stop request' (Y3) ON to OFF.

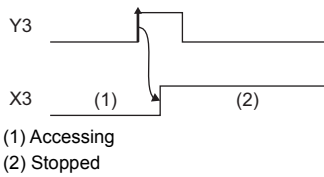

Insertion/removal method of an SD memory card

Make sure to stop the file access when removing or replacing an SD memory card.

Insertion procedure

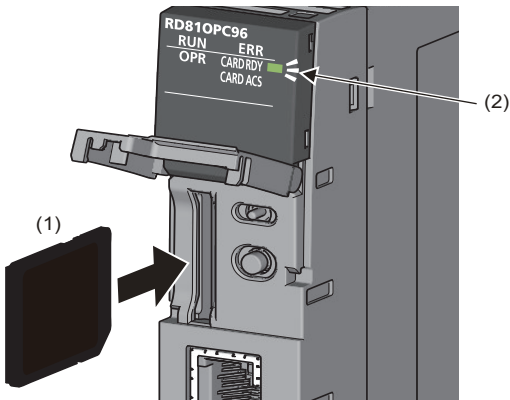

- 1.** Insert an SD memory card (1) straight into the SD memory card slot with its cutout pointed down.
Make sure it is not uplifted after inserting it.
If it is inserted insufficiently, it may cause malfunction due to poor contact.
- 2.** The CARD RDY LED (2) keeps flashing until the SD memory card is ready to be used. Once the CARD RDY LED(2) turns ON, the SD memory card can be used.

Removal procedure

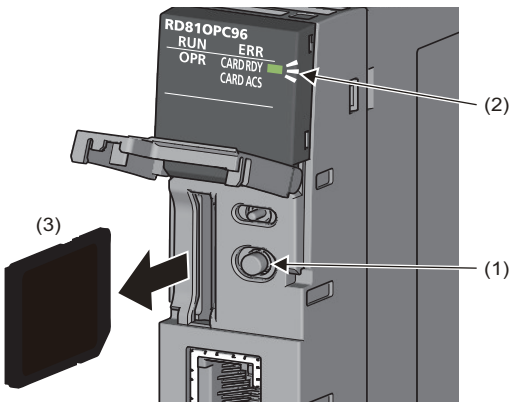

- 1.** Press the SD memory card lock switch (1) for one second or longer to stop the SD memory card access. (Refer to Page 43 File access stop processing method)
- 2.** The CARD RDY LED (2) is flashing while stopping the file access, and it turns OFF once the processing is completed.
- 3.** Push the SD memory card (3) in once, and pull it out straight.

Considerations for using an SD memory card

SD memory card to be used

Use a supported SD memory card. (☞ Page 50 SD memory card (sold separately, required))

If another SD memory card is used, data in the SD memory card may be corrupted or the system may stop.

When using an SD memory card used for other uses, make sure to format the card with the SD memory card diagnostic on the configuration tool. (📖 MELSEC iQ-R OPC UA Server Module User's Manual (Application))

Power-OFF or Reset of a CPU module

Data writing to an SD memory card may not be completed if the CPU module is turned OFF or reset during the writing.

Normally, the power supply can be turned OFF without stopping the file access since files are automatically repaired by the OPC UA server module when powering ON again.

However, infrequently, a file cannot be repaired completely by performing the above operations.

In addition, do not power OFF or reset a CPU module while formatting the SD memory card.

If any problem arises, power OFF or reset the CPU module after stopping the file access.

Check that the SD memory card is not being formatted since it can be formatted while stopping the file access.

For the important data, create backups in other media periodically.

Removing or replacing an SD memory card

Make sure to stop the file access before removing or replacing an SD memory card. (If the power is OFF and the file access is not stopped, turn the power ON and stop the file access.)

Otherwise, the data in the SD memory card being accessed may be corrupted or a file system failure may occur.

Check that the SD memory card is not being formatted since it can be formatted while stopping the file access.

The setting of OPC UA server module is saved in an SD memory card. Therefore, write the setting after the replacement as necessary.

SD memory card format

An SD memory card can be formatted with the SD memory card diagnostic on the configuration tool. (📖MELSEC iQ-R OPC UA Server Module User's Manual (Application))

Do not format an SD memory card with standard format commands of an operating system such as Windows.

Files in an SD memory card

Do not edit a file or folder in an SD memory card directly by inserting the card in a personal computer.

Make sure to use an SD memory card by inserting in an OPC UA server module.

SD memory card life

An SD memory card has a life (a limit on the number of times for writing data). For details, refer to the specification of an SD memory card to use.

5 SYSTEM CONFIGURATION

This chapter shows the system configuration of an OPC UA server module.

5.1 System Configuration

Overall system configuration

The following figure shows the overall system configuration when using an OPC UA server module.

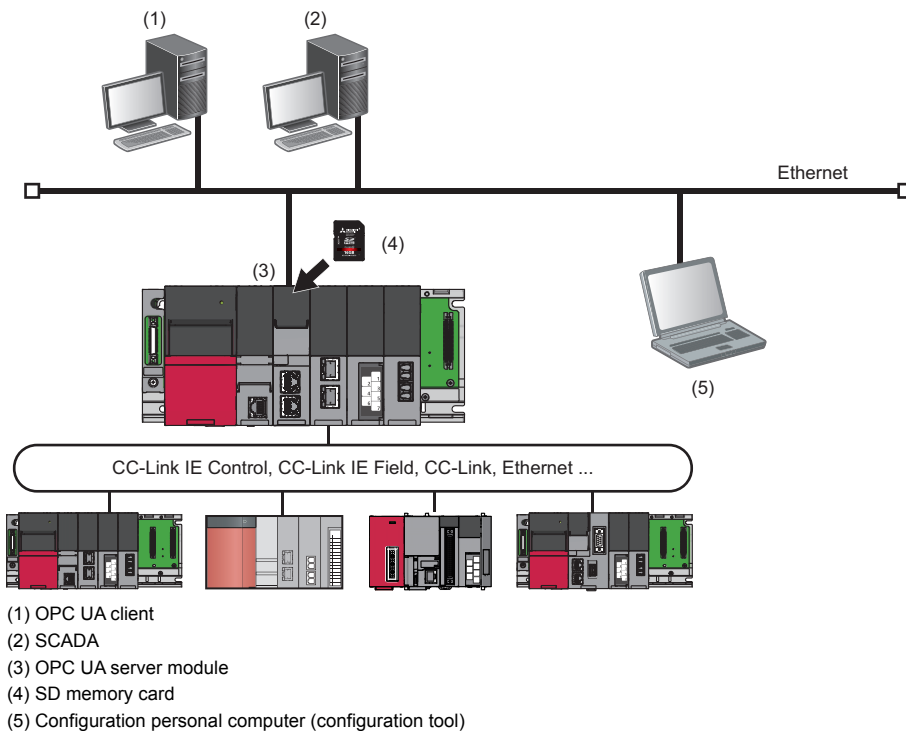

Point

For available CPU modules and the number of mountable ones, refer to the following:
MELSEC iQ-R Module Configuration Manual

System configuration for the initial setup, maintenance, and inspection

For the initial setup, maintenance, and inspection, connect an OPC UA server module and a configuration personal computer directly. (Page 48 Direct connection, Page 49 Considerations for direct connection)

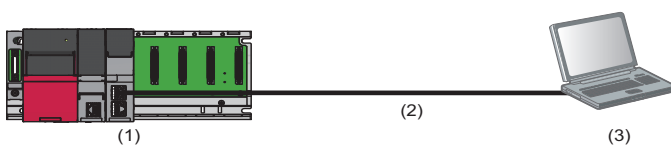

- (1) OPC UA server module
- (2) Ethernet (twisted pair cable)
- (3) Configuration personal computer

Point

For initial setting, only Ethernet port (CH1) can be used.
For using the Ethernet port (CH2), set a network in the network setting in the configuration Tool.
MELSEC iQ-R OPC UA Server Module User's Manual (Application)

System configuration during operation

This section shows the system configuration when operating an OPC UA server module.

Connection via a hub

An OPC UA server module can be connected to a configuration personal computer via a hub in a local area network. The IP address of an OPC UA server module needs to be specified.

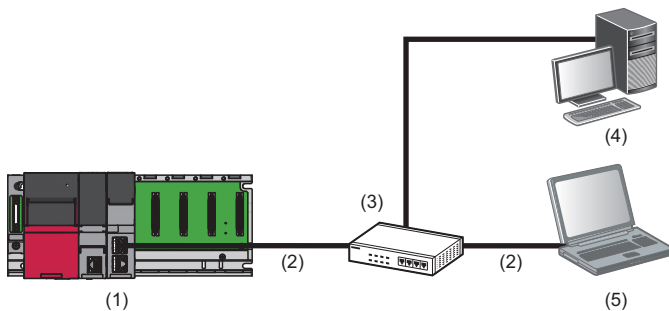

- (1) OPC UA server module
- (2) Ethernet (twisted pair cable)
- (3) Hub
- (4) OPC UA client
- (5) Configuration personal computer

Direct connection

An OPC UA server module can directly be connected to a configuration personal computer on a 1:1 basis with an Ethernet cable (crossover cable) without a hub.

The IP address of an OPC UA server module does not need to be specified for direct communication. (Broadcast is used.)



- (1) OPC UA server module
- (2) Ethernet (twisted pair cable)
- (3) Configuration personal computer

Considerations for direct connection

■Connecting to a LAN line

Do not communicate by connecting to LAN line directly.

This may increase the line load and affect the communications of other devices.

■Connections which are not direct connections

Do not set the direct connection in a configuration where a single OPC UA server module is connected to a single configuration personal computer via a hub as shown in the following figure.

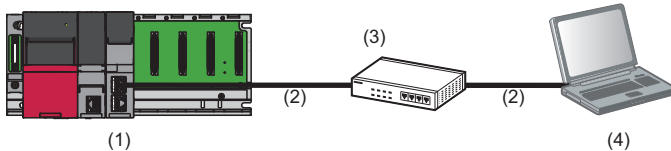

- (1) OPC UA server module
- (2) Ethernet (twisted pair cable)
- (3) Hub
- (4) Configuration personal computer

■Conditions where communication cannot be established directly

If the following condition is satisfied, communication by direct connection may not be established. In that case, review the settings of the OPC UA server module and configuration personal computer.

- When all bits of the IP address of an OPC UA server module that correspond to the '0' parts of a configuration personal computer subnet mask are ON or OFF

Ex.

IP address of an OPC UA server module: 64.64.255.255

IP address of a Configuration personal computer: 64.64.1.1

Subnet mask on a configuration personal computer: 255.255.0.0

- When all bits of the IP address of an OPC UA server module that correspond to the host address for each class of the IP address of a configuration personal computer are ON or OFF

Ex.

IP address of an OPC UA server module: 64.64.255.255

IP address of a Configuration personal computer: 192.168.0.1

Subnet mask on a configuration personal computer: 255.0.0.0

Point

- The IP addresses of each class are as follows:
Class A: 0.x.x.x to 127.x.x.x, Class B: 128.x.x.x to 191.x.x.x, Class C: 192.x.x.x to 223.x.x.x
- The host address for each class is the following '0' part.
Class A: 255.0.0.0, Class B: 255.255.0.0, Class C: 255.255.255.0

■Other considerations

- When the Windows firewall setting of a configuration personal computer is enabled

Disable the Windows firewall setting.

- When multiple IP addresses are enabled in a configuration personal computer

In the configuration where multiple IP addresses are enabled at the same time as shown below, do not set the setting for direct connection.

- An IP address is assigned to each Ethernet port of the configuration personal computer with multiple Ethernet ports.
- The wireless LAN setting is enabled in addition to the Ethernet port of an configuration personal computer.
- Multiple IP addresses are assigned to one network device (Ethernet port) of a configuration personal computer.

5.2 Connection device

This section shows the connectable devices to an OPC UA server module.

SD memory card (sold separately, required)

One SD memory card is required for using an OPC UA server module.

Use one of the following SD memory cards manufactured by Mitsubishi Electric.

Model name	Description
NZ1MEM-2GBSD	SD memory card 2 GB
NZ1MEM-4GBSD	SD memory card 4 GB
NZ1MEM-8GBSD	SD memory card 8 GB
NZ1MEM-16GBSD	SD memory card 16 GB

For using an SD memory card, make sure to refer to the following section. (☞ Page 45 Considerations for using an SD memory card)

Ethernet (twisted pair) cable (sold separately)

The Ethernet cables compliant with IEEE802.3 100BASE-T/100BASE-TX/10BASE-T standards can be used.

Transmission rate	Unshielded twisted pair cable (UTP cable) Shielded twisted pair cable (STP cable)	
	Straight cable	Crossing cable
1000 Mbps	Category 5e or higher	Category 5e
100 Mbps	Category 5 or higher	Category 5 or 5e
10 Mbps	Category 3 or higher	Category 3 to 5e

When using an Ethernet cable, make sure to refer to the considerations. (☞ Page 54 Wiring Considerations)

5.3 Operating Environment

This section shows the operating environment of the configuration tool.

Item	Description
Personal computer	A personal computer on which Microsoft® Windows® operates
CPU	Intel® Core™ 2 Duo 2 GHz or more recommended
Required memory	64-bit OS: 2 GB or more recommended 32-bit OS: 1 GB or more recommended
Display	Resolution 1024 × 768 pixels or higher
Hard disk free space	512 MB or more
Disk drive	DVD-ROM disk drive
Interface	Ethernet(IPv4) 1000BASE-T/100BASE-TX/10BASE-T
Operating system (English version) ^{*1,*2,*3,*4,*5}	Windows 10 (Home, Pro, Enterprise, Education) ^{*6} Windows 8.1, Windows 8.1 (Pro, Enterprise) ^{*7} Windows 8, Windows 8 (Pro, Enterprise) ^{*7} Windows 7 SP1 (Home Premium, Professional, Ultimate, Enterprise)

*1 When the following functions are used, this product may not run properly.

- Application start-up in Windows compatibility mode
- Fast user switching
- Remote desktop
- Power save mode (standby, hibernate, sleep)
- Windows XP Mode
- Windows Touch or Touch
- Modern UI
- Client Hyper-V
- Virtual environment (VMware®, Windows Virtual PC)
- Tablet mode
- Virtual desktop

*2 In the following cases, the screen of this product may not work properly.

- The size of a text and/or other items on the screen are changed to values other than default values (such as 96 DPI, 100%, and 9 pt).
- The resolution of the screen is changed in operation.
- The multi-display is set.

*3 Use the product as a standard user or an administrator.

*4 When '.NET Framework 4.0' and 'Visual C++ 2010 SP1 redistributable package (x86)' are not installed in a personal computer in which the setting tool is to be installed, approximately 500 MB of free space is required in the system drive to install them.

*5 When the Windows firewall setting is enabled, online functions may not work properly. In this case, disable the Windows firewall setting.

*6 When '.NET Framework 4.6 Advanced Services' is disabled, it is required to be enabled.

*7 When '.NET Framework 4.5 Advanced Services' is disabled, it is required to be enabled.

5.4 Supported Software Package

The following table shows the software package supporting an OPC UA server module.

Software package	Software version
GX Works3	1.035M or later

6 WIRING

This section shows the method for connecting an Ethernet cable to an OPC UA server module.

For connectable Ethernet cables, refer to the following:

☞ Page 50 Ethernet (twisted pair) cable (sold separately)

6.1 Wiring of an Ethernet cable

The following shows the connection and disconnection methods of an Ethernet cable.

Connection procedure

1. Check the insertion direction, and insert an Ethernet cable into an Ethernet port on the module until it clicks.
2. Check that the cable securely is connected by pulling it slightly.
3. Check the SPEED LED lighting status of the Ethernet port connected with the Ethernet cable. (☞ Page 15 PART NAMES)

Point

- The time required from when an Ethernet cable is connected to when the SPEED LED turns ON may vary. Normally, it turns ON in a few seconds. However, it may take longer because the linking-up processing is repeated due to the device condition on the line.
- When the SPEED LED does not turn ON, check if the connected Ethernet cable has any failure.
- The SPEED LED turns OFF when connecting with an Ethernet device on the network of which the transmission rate is 10 Mbps. Check the communication status by performing the PING test etc.

Disconnection procedure

1. Pull out the Ethernet cable while pinching the clip on the connector.

Considerations for 1000BASE-T/100BASE-TX connection

A communication error may occur due to the high frequency noise generated from a device other than a programmable controller depending on the installation environment.

The following shows the measures to be taken on the module side to prevent the influence of the high frequency noise.

- Do not bundle a cable with the main circuit or power cable, or do not place it near those lines.
- Place a cable in a duct.
- In the environment where a cable is susceptible to noise, use the STP cable.
- Change the target device connected with the module to one which communicates at 10 Mbps, and decrease the data transmission rate.

6.2 Wiring Considerations

- To establish a reliable system and fully use the functions of modules, a wiring that does not easily receive the effects of noise is required.
- Sufficient safety measures must be taken when constructing the IEEE802.3 1000BASE-T/100BASE-TX/10BASE-T networks.
Consult a specialist when handling the terminal processing of connection cable, installing trunk cables, etc.
- Use the cables compliant with IEEE802.3 1000BASE-T/100BASE-TX/10BASE-T standards. (📄 Page 50 Ethernet (twisted pair) cable (sold separately))
- For the connection on the target device side, check the specifications of the target device in advance.
- Place an Ethernet cable in a duct or clamp it.
Otherwise, the dangling cable may swing or inadvertently be pulled. It may cause a module or an Ethernet cable to damage or malfunction due to the poor contact.
- Protect the core wire in the connector of Ethernet cable or the port of the module to prevent touching by hand and sticking dirt or dust.
If any oil from your hand, dirt or dust sticks the core wire, it may increase the transmission loss and fail a data link.
- Check if the Ethernet cable used is disconnected, a short-circuit is generated, and the connector is properly connected.
- Do not use an Ethernet cable with the broken clip.
Doing so may cause the cable to unplug or malfunction.
- Hold the connector on the Ethernet cable when connecting or disconnecting it.
If the cable is pulled while being connected to the module, it may cause the module or Ethernet cable to damage or malfunction due to the poor contact.
- Attach the provided connector cover to protect the unused Ethernet port from dirt and dust.
- The maximum segment length of Ethernet cable is 100 m. However, the length may be shorter depending on the use environment of the cable. For details, contact the manufacturer of the cable used.
- The bending radius of the Ethernet cable is limited. For details, check the specifications of the Ethernet cable used.

7 INSTALLATION AND UNINSTALLATION

This chapter explains the procedures for installing and uninstalling MX OPC UA Module Configurator-R.

Considerations for installation and uninstallation

- Log on to a personal computer as a user with an administrator authority.
- Before installation, end all running applications on the operating system.
If software is installed while other applications are running, the product may not run normally.
- Install the software after changing the setting to prevent starting the update program automatically.
The installer may not run normally if an update program for either operating system or software of other companies such as Windows Update and Java® update may start automatically.
- After completing the installation, the computer may need to be restarted.
If the restart message appears, restart the computer before using it.

7.1 Installation Procedure

This section shows the installation procedure of MX OPC UA Module Configurator-R.

Operating procedure

1. Start the installer.

Double-click 'setup.exe' in the DVD-ROM with the MX OPC UA Module Configurator-R product.

2. Enter or select the necessary information according to instructions shown on the screen.

Windows firewall setting

When the firewall function of an operating system and security software are enabled, perform any of the following operations.

- ① Set the following programs to the firewall exception.

Program	Storage destination of an execution file (when the installation destination is C:\Program Files (x86)\MELSOFT.)
MELSEC iQ-R series OPC UA Server Module Configuration Tool ^{*1}	C:\Program Files (x86)\MELSOFT\ROPCUA\MxOpcUaModuleConfiguratorR.exe

*1 This setting is not required when the [Yes] button is selected on the screen below.

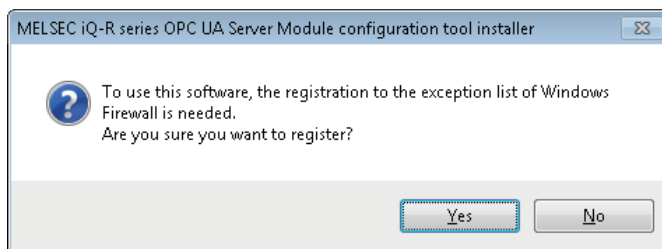

For the setting methods, refer to the manuals and online help of the operating system or security software used.

- ② Disable the firewall function.

Setting to associate the extension (.mxcfg) of a project file and a program

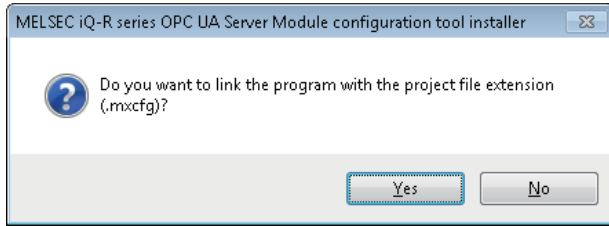

When the [No] button is selected on the screen above, MX OPC UA Module Configurator-R does not open by double-clicking a project file with the extension (.mxcfg). Perform the following operation to open the file.

Operating procedure

 [File] from the menu of MX OPC UA Module Configurator-R ⇒ [Open Project]

In another way, refer to the online help of an operating system and associate with a program.

Environment after installation

MX OPC UA Module Configurator-R is installed to a specified folder and registered in the start menu.

The following table shows the startup method and the maximum number of software, which can start at the same time, after installation.

Software	Startup method	Maximum No.
MX OPC UA Module Configurator-R	Click [MELSOFT] ⇒ [MX OPC UA] ^{*2} ⇒ [MELSEC iQ-R series OPC UA Server Module Configuration Tool] from Windows Start ^{*1}	1

*1 Select [All apps] in the Start screen or [Start] ⇒ [All Programs]/[All apps].

*2 Does not appear in Windows 8 or later.

7.2 Uninstallation Procedure

This configuration tool can be uninstalled on the control panel in Windows.

Disable the Windows firewall if it was set manually.

For the method to disable the Windows firewall, refer to the manuals and online help of the operating system and the security software used.

Environment after uninstallation

An installed program file, folder, and start menu are deleted after the uninstallation.

If there is data such as a project file, which was output after the installation, in a folder, the file/folder will not be deleted.

8 OPERATION EXAMPLE

This chapter shows the operation example of simple access in a system configuration including an OPC UA server module. The following example is for accessing the device (M0) of a CPU module from an OPC UA client.

8.1 Setup

System configuration

This section shows the setting for configuring a sample system including the following devices and software.

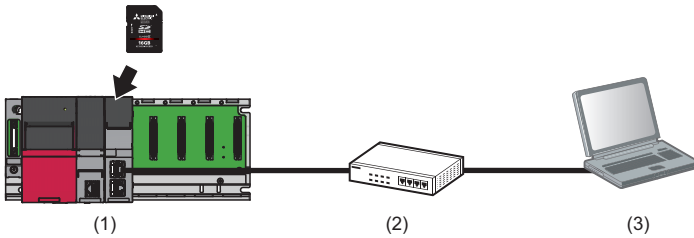

Device/Software		Product name/description	Reference	
(1)	Programmable controller system	Main base unit	R35B	
		Power supply module	R61P	
		CPU module	R08CPU	
		OPC UA server module	RD81OPC96	
		SD Memory Card	NZ1MEM-nGBSD ('n' indicates a number of bytes.)	
(2)	Twisted pair cable and hub	A cable and a hub compliant with IEEE802.3 1000BASE-T/100BASE-TX/10BASE-T standards	Page 50 Ethernet (twisted pair) cable (sold separately)	
(3)	Personal computer	A personal computer on which Windows operates	Page 51 Operating Environment	
	OS	Microsoft Windows 7 Professional Operating System (64-bit version)		
	Engineering tool	GX Works3	SWnDND-GXW3 ('n' indicates its version.)	GX Works3 Installation Instructions GX Works3 Operating Manual
	Configuration tool	MX OPC UA Module Configurator-R	SW1DND-ROPCUA-E	Page 55 INSTALLATION AND UNINSTALLATION

- The IP address of an OPC UA server module is '192.168.3.3'.
- The IP address of a personal computer is '192.168.3.100'.

Point

To set a setting of an CPU module, connect a personal computer and the CPU module with a USB cable.

Device setup

This section shows the setup procedures of devices.

Personal computer setting

Operating procedure

1. Install MX OPC UA Module Configurator-R.
2. Set the IP address of a personal computer to '192.168.3.100'.

This setting can be set on the "Internet Protocol Version 4 (TCP/IPv4) Properties" screen.

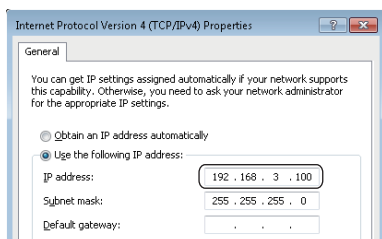

Programmable controller system setting

Operating procedure

1. Mount a power supply module, CPU module, and OPC UA server module on a main base unit.

 MELSEC iQ-R Module Configuration Manual

2. Insert an SD memory card into the OPC UA server module.

 Page 44 Insertion/removal method of an SD memory card

3. Set parameters and write them to the CPU module in the engineering tool.

 Page 39 Parameter setting

Point

For details on the parameter setting and programming in the engineering tool, refer to the following:

 GX Works3 Operating Manual

8.2 Setting of an OPC UA Server Module

This section shows the setting of an OPC UA server module in the configuration tool.

Setting procedure

Starting the configuration tool

1. Start the configuration tool.

Select [Start] ⇒ [All Programs] ⇒ [MELSOFT] ⇒ [MX OPC UA] ⇒ [MELSEC iQ-R series OPC UA Server Module Configuration Tool] from Windows Start.

Setting a network

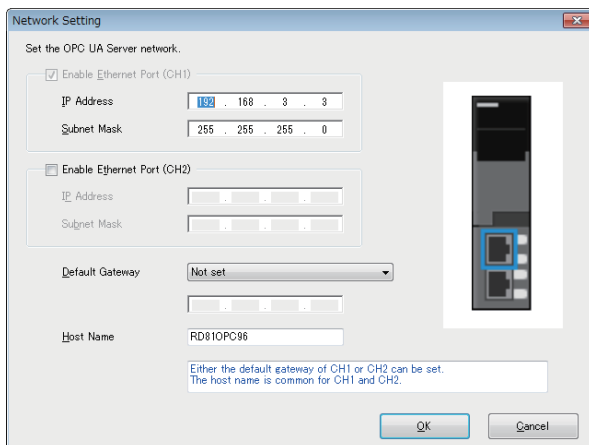

1. Select [Tool] ⇒ [Network Setting].



This setting is used as a default.

Setting an OPC UA server

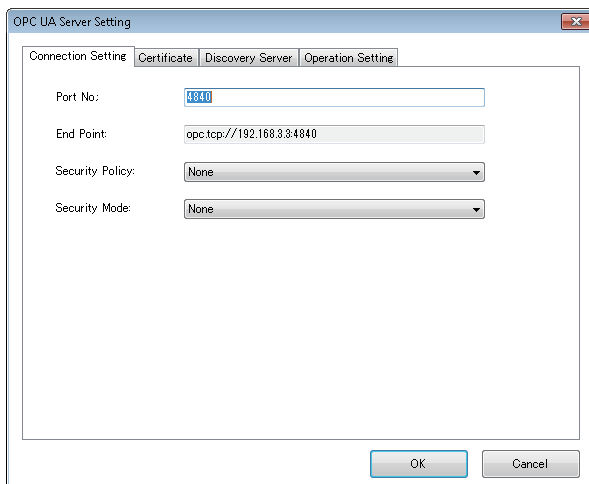

1. Select [Tool] ⇒ [OPC UA Setting].



- This setting is used as a default.
- When connecting from an OPC UA client, use this setting.

Setting the security

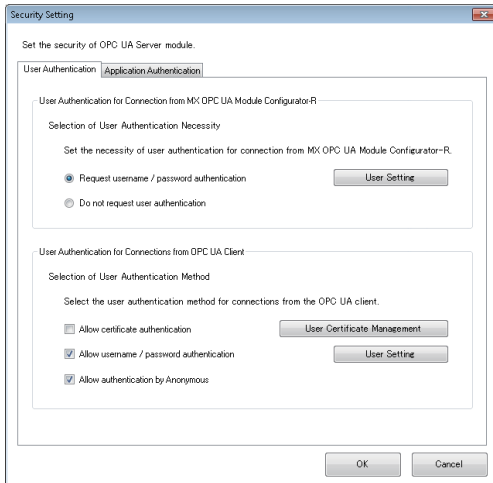

1. Select [Tool] ⇒ [Security Setting].

Point

This setting is used as a default.

Setting an access target device under the address space

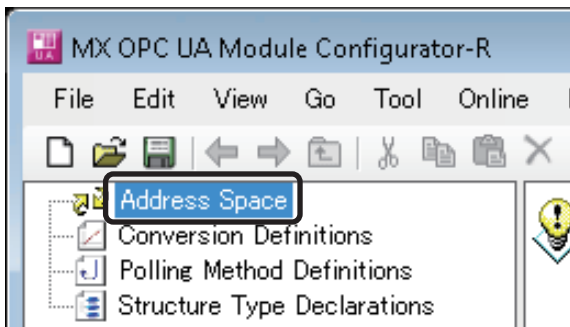

1. Select "Address Space" in the tree view.
2. Select [Edit] ⇒ [New Target Device].

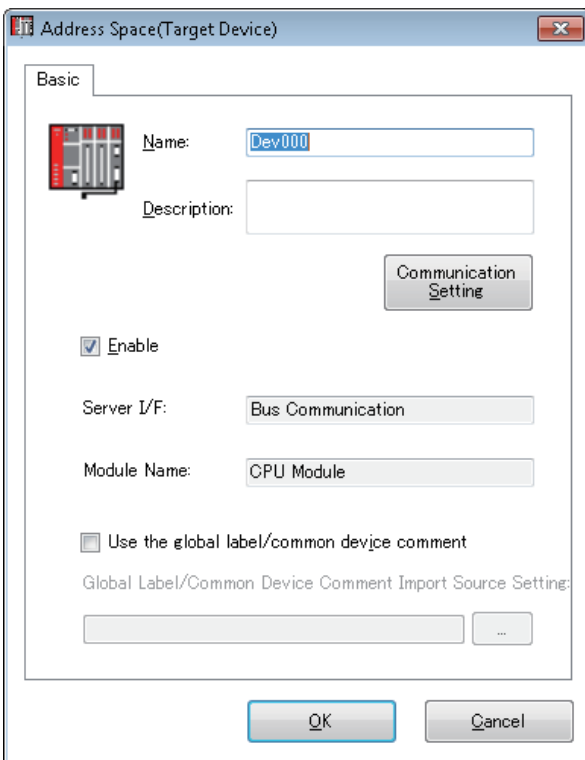

3. Click the [OK] button.

Setting a tag under the address space

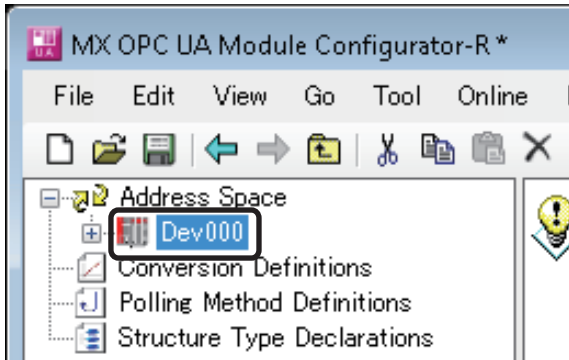

1. Select "Dev000" (🔴) under "Address Space" in the tree view.
2. Select [Edit] ⇒ [New Data Tag].

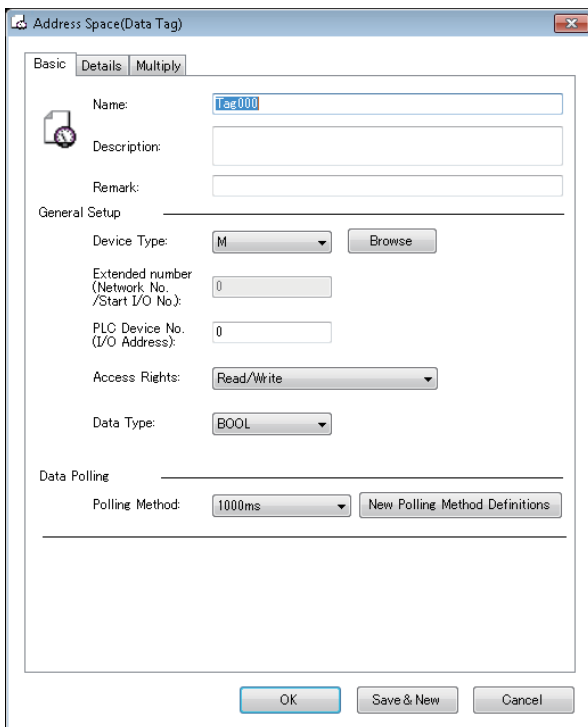

3. Click the [OK] button.

Setting a connection destination

Target Setting

Connection Destination Settings
Set the connection destination.

Connecting Method:

IP Address:

User Authentication Setting
Set the User Authentication.

Use the User Authentication

User Name:

Password:

1. Select [Online] ⇒ [Target Setting].
2. Enter a user name and a password, then click the [OK] button.

The following are set by default.

User name: RD81OPC96

Password: MITSUBISHI

Uploading a certificate to the trust list

Manage Application Certificate

Trusted Issuers

Trust List

File Path	Name	Issuer Name

Upload Download Delete

Revocation List

File Path	URL No.	Issuer Name

Upload Download Delete

Denied Certificate List

File Path	Name	Issuer Name

Download Delete Refresh

Server Certificate Upload Server Private Key Upload
Server Certificate Download Server Private Key Download
Server Certificate Delete Server Private Key Delete

Close

1. Select [Online] ⇒ [Manage Application Certificate].

2. Upload a client certificate to the trust list.

For the procedure, refer to the following:

📖 MELSEC iQ-R OPC UA Server Module User's Manual (Application)

Writing the setting

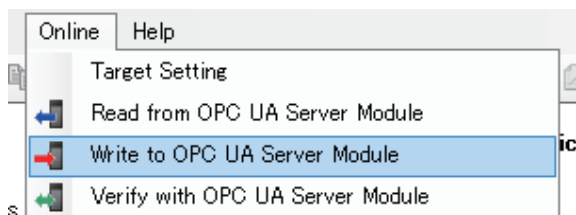

1. Select [Online] ⇒ [Write to OPC UA Server Module].
2. After completing the writing, reset the CPU module and start the OPC UA server module.

Restriction

If verifying a setting written to a module in the configuration tool the version of which is '1.01B' or later in the configuration tool the version of which is '1.00A', it cannot be verified correctly. Update the configuration tool to the latest version before verification.

8.3 Operation Check

This section shows the procedure to check whether an OPC UA client can access an OPC UA server.

1. Search an OPC UA server module from an OPC UA client, and connect the module.
2. Check whether the device (M0) of the CPU module can be read and written.

For the operation methods of an OPC UA client, refer to the manual of an OPC UA client to use.

Point

For MC Works64, add 'ua:' at the beginning of the endpoint URL of an OPC UA server module.
(Example) ua:opc.tcp://192.168.3.3:4840

APPENDIX

Appendix 1 External Dimensions

The following figures show the external dimensions of an OPC UA server module.

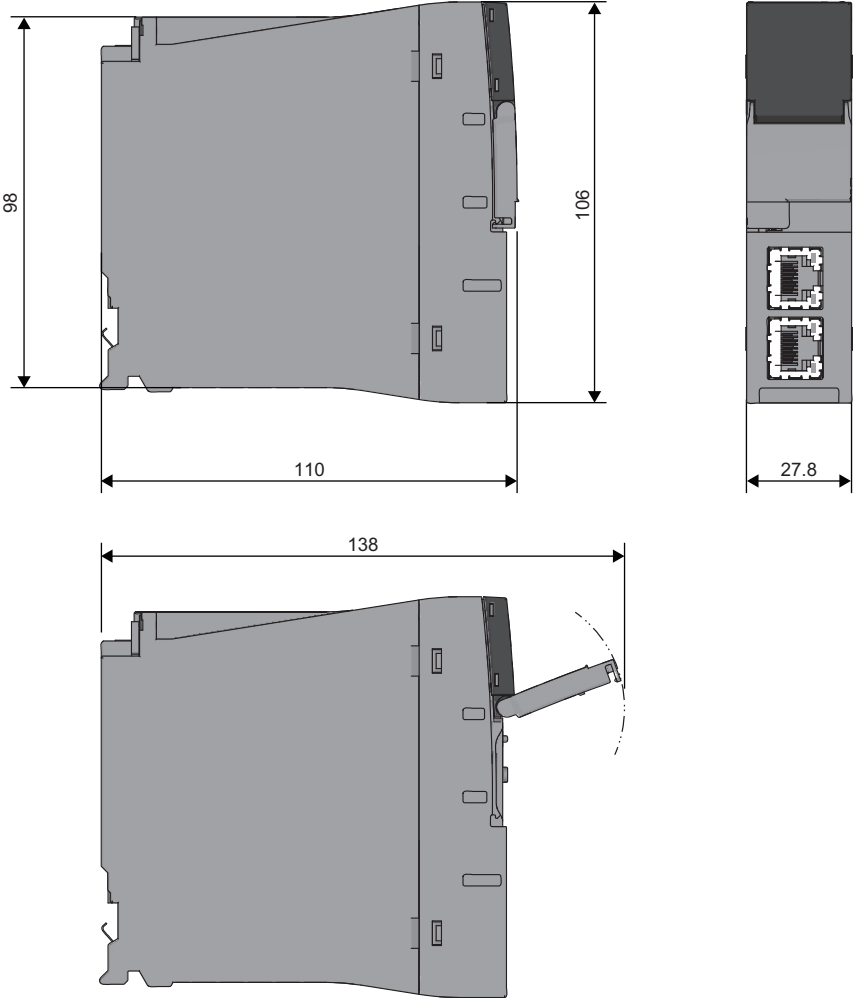

(Unit: mm)

MEMO

A

INDEX

A

Access specifications 21

C

Connection device 50

D

Direct connection 49

Display language switching 35

Dot matrix LED 15

Dot matrix LED display mode switch 16

E

Ethernet (twisted pair) cable 50

External dimension 64

F

Function list 30

I

Insertion/removal method of an SD memory card . 44

P

Parameter setting 39

Performance specifications 17

Procedure before operation 32

S

SD memory card 41,50

SD memory card format 46

MEMO

REVISIONS

*The manual number is given on the bottom left of the back cover.

Revision date	*Manual number	Description
April 2017	SH(NA)-081693ENG-A	First edition
October 2017	SH(NA)-081693ENG-B	■Added or modified parts Section 2.2
December 2018	SH(NA)-081693ENG-C	■Added or modified parts TERMS, Section 2.1, Section 3.1, Section 3.2, Section 4.2, Section 8.2
February 2019	SH(NA)-081693ENG-D	Partial correction
May 2019	SH(NA)-081693ENG-E	■Added or modified parts Section 2.1

Japanese manual number: SH-081691-E

This manual confers no industrial property rights of any other kind, nor does it confer any patent licenses. Mitsubishi Electric Corporation cannot be held responsible for any problems involving industrial property rights which may occur as a result of using the contents noted in this manual.

© 2017 MITSUBISHI ELECTRIC CORPORATION

WARRANTY

Please confirm the following product warranty details before using this product.

1. Gratis Warranty Term and Gratis Warranty Range

If any faults or defects (hereinafter "Failure") found to be the responsibility of Mitsubishi occurs during use of the product within the gratis warranty term, the product shall be repaired at no cost via the sales representative or Mitsubishi Service Company.

However, if repairs are required onsite at domestic or overseas location, expenses to send an engineer will be solely at the customer's discretion. Mitsubishi shall not be held responsible for any re-commissioning, maintenance, or testing on-site that involves replacement of the failed module.

[Gratis Warranty Term]

The gratis warranty term of the product shall be for one year after the date of purchase or delivery to a designated place. Note that after manufacture and shipment from Mitsubishi, the maximum distribution period shall be six (6) months, and the longest gratis warranty term after manufacturing shall be eighteen (18) months. The gratis warranty term of repair parts shall not exceed the gratis warranty term before repairs.

[Gratis Warranty Range]

- (1) The range shall be limited to normal use within the usage state, usage methods and usage environment, etc., which follow the conditions and precautions, etc., given in the instruction manual, user's manual and caution labels on the product.
- (2) Even within the gratis warranty term, repairs shall be charged for in the following cases.
 1. Failure occurring from inappropriate storage or handling, carelessness or negligence by the user. Failure caused by the user's hardware or software design.
 2. Failure caused by unapproved modifications, etc., to the product by the user.
 3. When the Mitsubishi product is assembled into a user's device, Failure that could have been avoided if functions or structures, judged as necessary in the legal safety measures the user's device is subject to or as necessary by industry standards, had been provided.
 4. Failure that could have been avoided if consumable parts (battery, backlight, fuse, etc.) designated in the instruction manual had been correctly serviced or replaced.
 5. Failure caused by external irresistible forces such as fires or abnormal voltages, and Failure caused by force majeure such as earthquakes, lightning, wind and water damage.
 6. Failure caused by reasons unpredictable by scientific technology standards at time of shipment from Mitsubishi.
 7. Any other failure found not to be the responsibility of Mitsubishi or that admitted not to be so by the user.

2. Onerous repair term after discontinuation of production

- (1) Mitsubishi shall accept onerous product repairs for seven (7) years after production of the product is discontinued. Discontinuation of production shall be notified with Mitsubishi Technical Bulletins, etc.
- (2) Product supply (including repair parts) is not available after production is discontinued.

3. Overseas service

Overseas, repairs shall be accepted by Mitsubishi's local overseas FA Center. Note that the repair conditions at each FA Center may differ.

4. Exclusion of loss in opportunity and secondary loss from warranty liability

Regardless of the gratis warranty term, Mitsubishi shall not be liable for compensation to:

- (1) Damages caused by any cause found not to be the responsibility of Mitsubishi.
- (2) Loss in opportunity, lost profits incurred to the user by Failures of Mitsubishi products.
- (3) Special damages and secondary damages whether foreseeable or not, compensation for accidents, and compensation for damages to products other than Mitsubishi products.
- (4) Replacement by the user, maintenance of on-site equipment, start-up test run and other tasks.

5. Changes in product specifications

The specifications given in the catalogs, manuals or technical documents are subject to change without prior notice.

TRADEMARKS

Ethernet is a registered trademark of Fuji Xerox Co., Ltd. in Japan.

Intel is either a registered trademark or a trademark of Intel Corporation in the United States and/or other countries.

Microsoft and Windows are either registered trademarks or trademarks of Microsoft Corporation in the United States and/or other countries.

Unicode is either a registered trademark or a trademark of Unicode, Inc. in the United States and other countries.

The company names, system names and product names mentioned in this manual are either registered trademarks or trademarks of their respective companies.

In some cases, trademark symbols such as [™] or [®] are not specified in this manual.

SH(NA)-081693ENG-E(1905)KWIX

MODEL: RD81OPC96-U-IN-E

MODEL CODE: 13JX63

mitsubishi electric corporation

HEAD OFFICE : TOKYO BUILDING, 2-7-3 MARUNOUCHI, CHIYODA-KU, TOKYO 100-8310, JAPAN
NAGOYA WORKS : 1-14, YADA-MINAMI 5-CHOME, HIGASHI-KU, NAGOYA, JAPAN

When exported from Japan, this manual does not require application to the
Ministry of Economy, Trade and Industry for service transaction permission.

Specifications subject to change without notice.